

SPIRAL MIXER MAG-R 80

Code : B600006AV-0002

400V – 50HZ - Tri



Photo not contractual

INSTRUCTION MANUAL

Important: read this handbook before running

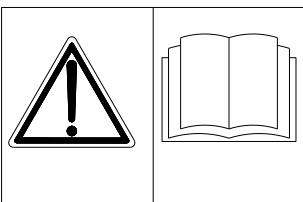

This instruction and maintenance manual forms an integral part of the machine; it must be preserved for the full life of the machine and must be passed on to any subsequent users.

The manual contains all the instructions necessary for the transport, installation, start-up, use, maintenance and disposal of the machine and must therefore be read and understood before proceeding with any of these operations. It must be handled with care and stored where it is readily available for consultation both by the machine operators and the technicians. The observance of the contents of the manual ensures the safe, correct and optimal operation of the machine itself, as well as the safety of the machine operator and other persons authorised to come into contact with the machine.

Code : B600006AV-0002

400V - 50HZ - Tri

Version :

CONTENTS

1	“EC” DECLARATION OF CONFORMITY -----	3
2	FOOD CONTACT DECLARATION -----	3
3	MACHINE SPECIFICATION SHEET -----	4
4	SYMBOLS AND PERSONNEL QUALIFICATIONS -----	4
5	TECHNICAL FEATURES -----	6
5.1	SIZE -----	6
5.2	TECHNICAL CHARACTERISTICS -----	6
5.3	DIMENSIONS AND WEIGHT OF THE PACKED MACHINE -----	7
6	IDENTIFICATION OF THE MACHINE -----	7
7	SAFETY INSTRUCTIONS -----	8
7.1	SAFETY MEASURES -----	8
7.2	SAFETY DEVICES -----	8
7.3	ACCIDENT PREVENTION -----	9
7.4	MACHINE TESTS CARRIED OUT BY THE MANUFACTURER -----	9
8	RISKS, PROHIBITIONS, OBLIGATIONS -----	10
9	DESCRIPTION OF THE MACHINE AND ITS USE -----	11
9.1	INTENDED USE OF THE MACHINE -----	11
9.2	PERCENTAGES OF INGREDIENTS -----	11
9.3	MACHINE STRUCTURE -----	11
9.4	GENERAL MACHINE OPERATION -----	12
10	PRESERVATION OF THE MACHINE -----	12
10.1	PRESERVATION OF THE MACHINE BEFORE A LONG PERIOD OF DISUSE -----	12
10.2	STORAGE OF THE PACKED MACHINE -----	12
10.3	STORAGE OF THE UNPACKED MACHINE -----	12
11	HANDLING AND INSTALLING THE MACHINE -----	13
11.1	OPERATION A: UNPACKING, LIFTING THE MACHINE AND CONNECTING IT TO THE POWER SUPPLY -----	13
11.2	CONNECTION TO THE POWER SUPPLY -----	15
11.3	OPERATION B: LEVELLING THE MACHINE AND FASTENING IT TO THE FLOOR -----	16
11.4	OPERATION C: REMOVING THE BOWL TROLLEY FROM THE MACHINE -----	17
11.5	OPERATION D: INSERTING THE BOWL TROLLEY AND PREPARING THE MACHINE FOR USE -----	17
11.6	GENERAL OPERATING CONDITIONS -----	18
12	CLEANING THE MACHINE -----	18
12.1	CLEANING THE BODY OF THE MACHINE -----	18
12.2	CLEANING THE INSIDE OF THE BOWL AND THE MIXING TOOLS -----	18
13	OPERATING PROCEDURES -----	19
13.1	PRELIMINARY MACHINE CHECK-UP -----	19
13.2	LOADING THE INGREDIENTS TO BE KNEADED -----	19
13.3	EXECUTING A WORK CYCLE -----	20
13.4	WARNINGS RELATIVE TO REPEATED INTERRUPTIONS OF A WORK CYCLE -----	20
13.5	STOPPING THE MACHINE -----	20
13.6	UNLOADING THE KNEADED DOUGH -----	20
14	PERIODICAL INSPECTIONS, CLEANING AND MAINTENANCE OF THE MACHINE -----	21
14.1	CLEANING PROCEDURES AND PERIODICAL INSPECTIONS -----	21
14.2	INSPECTION OF THE SAFETY DEVICES -----	21
14.3	WEEKLY, MONTHLY, ANNUAL MAINTENANCE PROCEDURES -----	23
14.4	ADJUSTMENT OF THE BELT TENSION AND REPLACEMENT OF THE TRANSMISSION BELTS -----	24
15	TROUBLE SHOOTING -----	24
16	DISASSEMBLING AND DISPOSING OF THE MACHINE -----	24
16.1	MAIN COMPONENTS -----	24
16.2	DISASSEMBLY AND DISPOSAL OF THE MACHINE -----	24

SPIRAL MIXER MAG-R 80

Date création : 12-09-2012

Date révision :

Code : B600006AV-0002

400V - 50HZ - Tri

Version :

17	OPERATING MODES FOR CONTROL PANEL -----	25
17.1	FRONT CONTROL PANEL FOR DOUGH MIXING FUNCTIONS -----	25
17.2	LEFT- AND RIGHT-HAND SIDE CONTROL PANELS FOR MIXER HEAD MOVEMENTS -----	27
17.3	TIMER-CONTROLLED OPERATING MODES-----	28
17.4	MANUAL OPERATING -----	32
17.5	GENERAL REMARKS-----	33
18	SPECIAL MAINTENANCE PROCEDURES -----	34
19	EXTRAORDINARY MAINTENANCE -----	35
19.1	ADJUSTMENT OF THE BOWL FRICTION WHEELS -----	35
19.2	MAINTENANCE OF THE UPPER TRANSMISSION ELEMENTS -----	36
19.3	MAINTENANCE OF THE HYDRAULIC UNIT AND FAN IN THE MACHINE BASE -----	36
19.4	ACCESS TO THE HYDRAULIC HEAD CYLINDER AND HOOK -----	37
19.5	ADJUSTING THE PRESSURE SWITCHES OF THE HYDRAULIC UNIT -----	39
19.6	HYDRAULIC DIAGRAM -----	41
20	EXPLODED VIEWS OF MAG-R 80 -----	42
20.1	GENERAL DRAWING -----	42
20.2	SPIRAL - BVB305023 -----	43
20.3	SPIRAL MOTOR - BVB305117 -----	44
20.4	GALET DE FRICTON - BVB305313 -----	45
20.5	RETURN PULLEY - BVB305312 -----	46
20.6	BOWL MOTOR - BVB305405 -----	47
20.7	STOP - BVB305607 -----	48
20.8	SAFETY FENCE - BVB305750 -----	49
20.9	BOWL TROLLEY - BVB305208 -----	50
20.10	BOWL COVER - BVB305729 -----	52
20.11	FRAME - BVB306121 -----	54
20.12	HYDRAULIC STATION -----	56
21	WIRING DIAGRAMS: BVBE01056 -----	57

SPIRAL MIXER MAG-R 80

Date création : 12-09-2012

Date révision :

Code : B600006AV-0002

400V - 50HZ - Tri

Version :

1 "EC" DECLARATION OF CONFORMITY



Etiquette à coller

"Declares that the machine here above designed (Type, Make, Number) has been complied with the essential regulation of the directives 2006/42/CE (Machines), 2004/108/CE (EMC), and the corresponding standards".

Le Président Directeur Général de VMI est autorisé à faire constituer le dossier technique tel que requis par la directive 2006/42/CE



ZI Nord – Rue Joseph Gaillard - 85607 MONTAIGU Cedex – France

Montaigu,

D.SOUMET
President Directeur Général (CEO)

2 FOOD CONTACT DECLARATION

Etiquette à coller

Declares that the equipment meets the essential requirements of the European Regulation 1935/2004 ability of materials to be in contact with food.



ZI Nord – Rue Joseph Gaillard - 85607 MONTAIGU Cedex – France

Montaigu,

D.SOUMET
President Directeur Général (CEO)



VMI - Pétrins & Mélangeurs
Zone Industrielle Nord - 85607 MONTAIGU
Tél : 33 (0)2 51 45 35 35 Fax : 33 (0)2 51 06 40 84
Http : //www.vmi.fr – E-mail : comm.ind@vmi.fr

3 / 57

SPIRAL MIXER MAG-R 80

Date création : 12-09-2012

Date révision :

Code : B60006AV-0002

400V - 50HZ - Tri

Version :



3 MACHINE SPECIFICATION SHEET

Article number:	B60006AV-0002
Machine Description:	SPIRAL MIXER WITH REMOVABLE BOWL MAG 80 RB 2V TIMER SITEC 72X144
Number of speeds:	2
Voltage (V):	400V
Frequency (Hz):	50HZ
Number of phases:	3
Total power absorbed (kW):	8,55
Total current absorbed (A):	17,5
Conformity:	CE

4 SYMBOLS AND PERSONNEL QUALIFICATIONS

The person responsible for safety in the company and in the production department, when selecting the personnel to operate the machine, must select someone suitable for the job according to local law and must, furthermore, take into consideration the person's training, physical and psychological conditions (stability, sense of responsibility, etc.). Furthermore, once selected, the personnel assigned to operate the machine must be suitably trained (based on personal aptitude and capacity), which includes the full comprehension of this manual to ensure that the operator knows the machine, its functions, its behaviour and how to correctly execute each procedure pertinent to the machine operation in absolute safety.

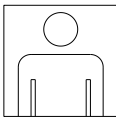
The following table indicates the symbols and corresponding, required qualifications for the personnel operating on the plant, which are used throughout this manual to specify the qualification necessary to implement a specific task.

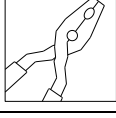
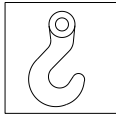
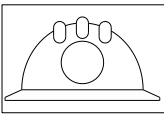
Symbole	Description	Characteristics/Qualifications
	MACHINE OPERATOR	A person in good health, that has been suitably trained to operate the machine (i.e. that has a good knowledge of: the machine functions, the machine regulations, the safety devices and protections installed on the machine, the possible work cycles, how to program a work cycle, the type of ingredients which can be used, as well as the corresponding maximum quantities allowed). The person must have carefully read and understood this manual for the use and maintenance of the machine.
	ELECTRICAL SERVICE ENGINEER	A person in good health, with the qualification of electrical service engineer, that has carefully read and understood this manual for the use and maintenance of the machine.
	MECHANICAL SERVICE ENGINEER	A person in good health, with the qualification of mechanical service engineer, that has carefully read and understood this manual for the use and maintenance of the machine.
	MECHANICAL SERVICE ENGINEER	A person in good health, qualified to handle loads, that has carefully read and understood this manual for the use and maintenance of the machine.
	CLIENT ASSISTANCE: C/O the manufacturer	Addresses the following requests for: <ul style="list-style-type: none">• updates of the manual;• telephonic assistance regarding machine functions, start-up and failures;• spare parts;• machine repairs;• system overhaul;

N.B. This machine must not be used/intervened upon by persons with any type of electronic implants (e.g. pacemaker)

SPIRAL MIXER MAG-R 80

Date création : 12-09-2012





Date révision :

Code : B600006AV-0002

400V - 50HZ - Tri

Version :

The following table indicates the warning and safety labels present on the machine and in this manual, which point out possible dangers related to the machine and/or to a specific task being implemented.

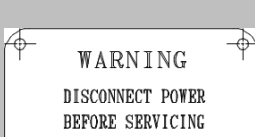
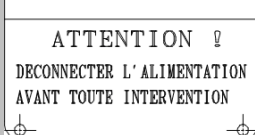
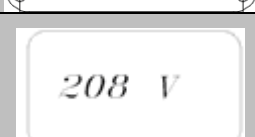
Warning and Safety Label/Symbol	Description
ATTENTION	This type of warning invites the competent person implementing a specific task to pay attention while carrying out the required manoeuvres. Non-observance of this warning can damage the machine and/or injure the persons assigned to the machine.
	This symbol indicates a general state of danger for the personnel assigned to operate on the machine and/or for the machine itself.
	This symbol indicates the presence of live parts. Before carrying out any type of intervention on the machine, interrupt the power supply to the machine by turning off the main switch and ensuring that the electrical panel on the machine and the machine power cable are isolated from the main power supply in a safe manner for the entire duration of the intervention, without accidental risk of re-energising of the power supply !
	This symbol indicates the presence of moving members and, therefore, the risk of entrapment.
	This symbol indicates the risk of being crushed.
 	This warning label indicates that the user must disconnect the power before servicing the machine.
	This label indicates the electrical voltage (e.g. 208 V, for this particular example).

SPIRAL MIXER MAG-R 80

Date création : 12-09-2012

Date révision :

Code : B600006AV-0002

400V - 50HZ - Tri

Version :

5 TECHNICAL FEATURES

5.1 Size

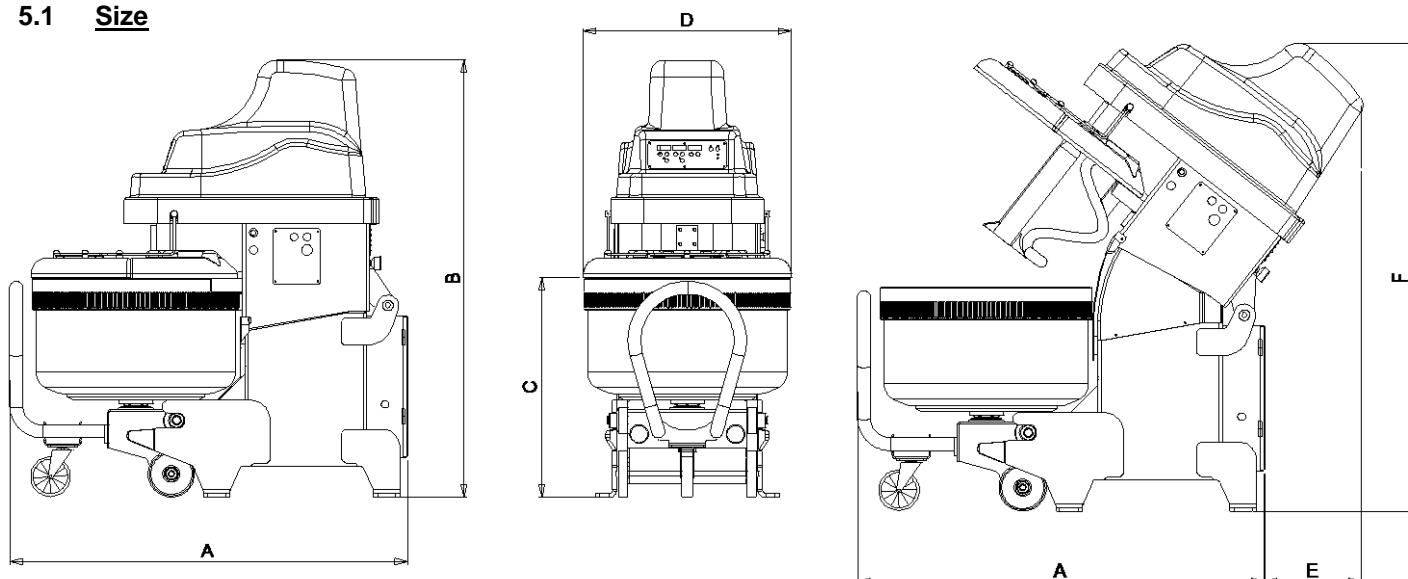

Model	Weight (kg)	Bowl capacity (l)	Power of spiral tool motor in 2 nd speed (kW)	A (mm)	B (mm)	C (mm)	D (mm)	E (mm)	F (mm)
MAG-R 80	650	130	8	1430	1660	830	710	360	1735

5.2 Technical characteristics

The table below contains the main technical characteristics of the machine.

TECHNICAL MACHINE DATA	MAG-R 80
Maximum Dough capacity (kg)	80
Maximum Flour capacity (kg)	50
Bowl volume (l)	154
Bowl diameter (mm)	680
Floor to bowl rim height (mm)	830
Length (mm)	1430
Width (mm)	710
Height with head closed (mm)	1660
Height with head open (mm)	1735
Weight (kg)	650
Power of spiral tool motor (kW) (1 st /2 nd speed)	4/7,8
Power of bowl motor (kW)	0,75
Power of hydraulic unit motor (kW)	0,75

SPIRAL MIXER MAG-R 80

Date création : 12-09-2012

Date révision :

Code : B600006AV-0002

400V - 50HZ - Tri

Version :

5.3 dimensions and weight of the packed machine

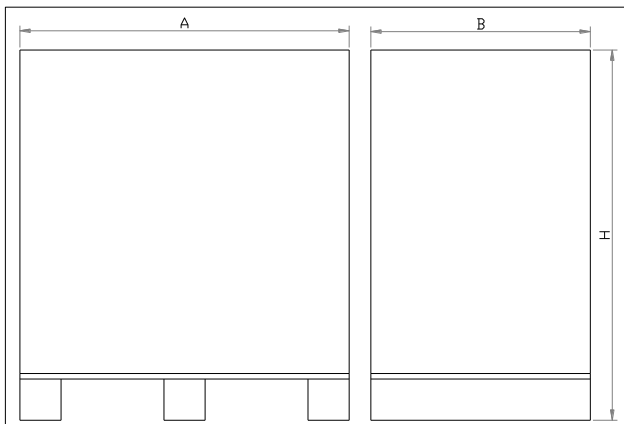

WOODEN CRATE		
MAG-R 80	AxBxH(cm)	Gross Weight(kg)
	180x105x200 (h)	750
WOODEN BOX		
	AxBxH(cm)	Gross Weight(kg)
	180x105x200 (h)	800

6 IDENTIFICATION OF THE MACHINE

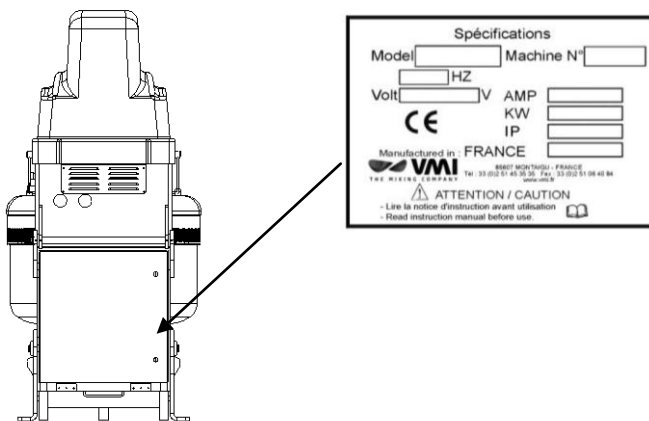

A serial plate, similar to the one illustrated above, is located at the back of the machine. It specifies:

- the type of conformity (CE)
- the details of the manufacturer
- the type of machine
- the serial number
- the year of construction
- the voltage, frequency and number of phases
- the total power absorbed (kW).

The electrical characteristics (voltage, frequency, number of phases and power absorbed) are specified in this manual under the section "Machine specifications" and in Appendix 2, as well as on the motor serial plates.

7 SAFETY INSTRUCTIONS

The obligatory safety measures, which must be adopted in order to ensure the safe use of the machine, are listed below. The symbols and signs appearing in the various sections of the manual indicate the qualifications required by the persons assigned to a specific task and the corresponding risk level. The plant manager is personally responsible for the training of suitably qualified personnel assigned to a specific task.

7.1 Safety measures

- The space surrounding the machine and related devices must be well illuminated, clear and clean.
- The personnel assigned to operate the machine must be physically well, psychologically stable and must wear suitable clothing (anti-slip safety shoes, close-fitting sleeves with closed shirt cuffs, gloves, mask and safety glasses, as required for the assigned task). It is absolutely forbidden to wear loose-fitting garments, materials or accessories (ties, torn garments, open jackets, loose pieces of materials etc.) to avoid the risk of entrapment. N.B. This machine must not be used/intervened upon by persons with any type of electronic implants (e.g. pacemaker)
- It is necessary to respect the maximum quantity of dough which can be kneaded for the specific machine, which can vary, depending on the percentages of the ingredients used.
- During maintenance and cleaning operations, the personnel assigned to these tasks must turn off the main switch and disconnect the machine from the electrical supply ensuring that the electrical panel on the machine and the machine power cable are isolated from the main power supply in a safe manner for the entire duration of the intervention, without accidental risk of re-energising of the power supply.
- The service engineer must wear protective clothing suitable for the task to be carried out; clothing which must offer protection against organic, chemical, biological, mechanical and/or electrical risks.
- When working with the machine, it is always necessary to observe the safety warnings and signs on the machine itself, in the work environment and on the products used, which point out, for example:
 - electrical, mechanical or thermal risks
 - the risk of slipping on wet or greasy surfaces
 - the risk of allergies to substances or irritations which can arise from products used in the production process or cleaning procedures.

Non-observance of the safety warnings and signs can lead to minor or major injuries.

7.2 Safety devices

The machine is equipped with safety devices which protect both the operator and the machine itself. Under no circumstances must they be removed, tampered with or modified in any way. It is necessary to periodically check that they function correctly.

- *Main switch (external)*: Turned off, it interrupts the electrical supply to the machine, permitting maintenance operations to be carried out in absolute safety.
- *Thermal switch (internal)*: It interrupts the electrical supply when the electric motor overheats.
- *Thermal overload switch (internal)*: It interrupts the electrical supply to the motor when excessive electrical current is absorbed.
- *Emergency switch (external)*: It interrupts the electrical supply to the machine, guaranteeing the complete safety of the machine and operator.
- *Fixed protective covers (external)*: All the fixed covers (fastened with screws or mechanical blocks) protect against heat and must not be removed, except by suitably qualified personnel carrying out maintenance operations in the specified manner and according to the safety standards in force. After any maintenance procedures, all the protective covers must be correctly re-positioned and securely fastened, before starting up the machine again.
- *Mobile protective bowl cover (external)*: The opening of the mobile protective bowl cover activates microswitches which interrupt the machine functions and do not allow it to operate unless the mobile protective cover is completely closed.

Note: When one of the safety systems is activated, the time taken for the spiral and bowl rotation to stop is not more than 4 seconds; this time interval is a result of the inertia. An immediate stop would cause stresses and fatigue failures.

SPIRAL MIXER MAG-R 80

Date création : 12-09-2012

Date révision :

Code : B600006AV-0002

400V - 50HZ - Tri

Version :

7.3 Accident prevention

Before starting up the machine:

Read this manual carefully. Ensure no children, animals or unauthorised persons are in the vicinity of the machine. Carefully check that the machine and external safety devices function correctly.

During machine operation:

Never leave the machine unattended. Pay attention to abnormal noises or machine behaviour. Keep away from moving members. Never open the mobile protective cover before the spiral tool has completely stopped rotating.

Upon completion of a work cycle:

Empty the contents of the machine bowl completely. Turn off the main switch and disconnect the machine from the electrical supply ensuring that the electrical panel on the machine and the machine power cable are isolated from the main power supply in a safe manner for the entire duration of the intervention, without accidental risk of re-energising of the power supply. Clean the machine, as per the procedures specified in this manual.

7.4 Machine tests carried out by the manufacturer

The manufacturer, before placing a machine on the market, carries out a series of tests to ensure that the machine functions correctly:

- Functional tests to check the electrical system and grounding.
- Functional tests to check the mixer functions.
- Tests to check the AERIAL NOISE level: less than 70 dB (A).

8 RISKS, PROHIBITIONS, OBLIGATIONS



It is prohibited to put out fires with water



It is prohibited to start up the machine before having checked the safety devices



It is prohibited to clean the machine in the presence of moving members



It is obligatory to disconnect the machine before carrying out any intervention on the machine itself. In particular: disconnect the machine from the electrical supply by ensuring that the electrical panel on the machine and the machine power cable are isolated from the main power supply in a safe manner for the entire duration of the intervention, without accidental risk of re-energising of the power supply.



It is obligatory to ground the machine.

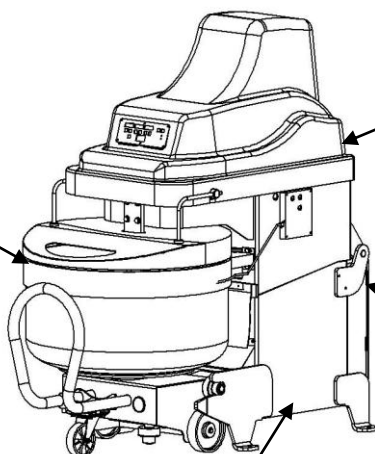

ATTENTION!

- Wear the correct protective clothing during all interventions.
- Carefully clean the machine; the products used in the production process can cause allergies or infections.
- Do not place heavy or dangerous objects on top of the machine.
- Do not place objects or accessories through the opening in the protective bowl cover.
- Do not remove the safety devices and the protective covers.

9 DESCRIPTION OF THE MACHINE AND ITS USE

9.1 Intended use of the machine

This line of removable bowl spiral mixers, suitable for semi-industrial and industrial use requiring high performance and professional features, has been designed for the purpose of kneading food dough which has as primary ingredients flour and water.

A rotating spiral tool, as a result of the powerful mechanical action of the mixer, rapidly and efficiently amalgamates, mixes, refines, kneads and incorporates air into the dough contained in the bowl. Originally conceived for the preparation of bread dough, the excellent results achieved in terms of amalgamation of the ingredients and oxygenation of the dough make this machine appropriate for mixing any leavened dough or dough for baked products composed of the following ingredients: any type of flour, water, yeast, fats-butter, sugar, legally-approved food essences and food colourings, salt, liqueurs and other ingredients suitable for bread and confectionery products. This line of mixers is not suitable for mixtures with less than 55% humidity. The maximum time interval of continuous use and the corresponding minimum time interval of rest for this mixer vary according to the recipe used (type of dough being kneaded); therefore, the user must refer to the manufacturer with the recipe for this information..

9.2 Percentages of ingredients

Based on the percentage of each ingredient, there is a maximum quantity of each ingredient which can be introduced into the bowl in order to respect the maximum dough capacity specified for the mixer.

For additional information on the maximum dough capacity and percentage of flour for a specific mixer, refer to Appendix 2..

9.3 Machine structure

The mixer is composed of the following components:

- A robust, steel body (1) (reinforced with metal profiles where the mechanical stress is greater) contains and supports the various machine components.
- The upper transmission group (located under the head cover (2)) rotates both the spiral tool (3) and the bowl (5). A main, powerful motor, by means of belts with low elongation properties, supplies the spiral with the necessary torque, while a separate motor drives the bowl, permitting it to rotate in both directions.



SPIRAL MIXER MAG-R 80

Date création : 12-09-2012

Date révision :

Code : B600006AV-0002

400V - 50HZ - Tri

Version :

- The spiral tool (3), as a result of its shape and movement, mixes and refines the ingredients by pushing them against the breaking column (4) and the sides of the bowl (5).
- The bowl (5), as a result of its rotation, constantly brings dough still to be kneaded under the spiral tool. A special thrust roller unit (composed of one thrust roller assembly in the 80-120 kg models and two thrust roller assemblies in the 160-300 kg models) guides the bowl rotation, while the milled border of the bowl guarantees the necessary grip, even in the presence of fat mixtures.
- The front control panel (10), located on the head cover, contains all the control and program logic. It executes each programmed work cycle and, by means of servomechanisms in the electrical panel (6), located at the back of the machine, drives the various motors in the programmed manner for the programmed time. The two identical side control panels (11), located on each side of the machine for practical purposes, contain the Emergency push button and the "Head Down" push button to lower the machine head.
- The hydraulic unit and the reliable electromagnet are located inside the base (7). The former controls the ascent and descent of the machine head while the latter holds the bowl trolley in place against the machine.
- The safety covers for the bowl (8-9), upper transmission group (2) and lower transmission group (not visible because located under the base (7)) serve to protect persons from accidentally coming into contact with the moving members of the machine.
- The mobile safety bowl cover (9), if opened during a work cycle, stops the machine by means of a microswitch.

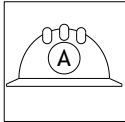

The adjustment of the minimum opening of the mobile bowl safety cover required to activate the microswitch is carried out by the manufacturer, in the manufacturing location, during the machine test phase. Any subsequent modification to the original manufacturer settings can only be carried out by the manufacturer's authorised personnel.

9.4 General machine operation

of operating mode and the corresponding operating times). Place the water, flour and the other ingredients necessary for the dough into the bowl in the required quantities (not exceeding the maximum quantities allowed – refer to Appendix 2). Insert the bowl carriage into the machine, lower the machine head, ensure that the movable bowl cover is closed and start the machine by pressing the Start button. The machine carries out the work cycle in the selected manner for the set time. Upon completion of the work cycle the machine head opens and the bowl carriage is released. It is possible to stop the machine at any time by pressing the Stop button and to start it again by pressing the Start button. The detailed description of the control panel and its use is described in detail in Appendix 1.

10 PRESERVATION OF THE MACHINE

10.1 Preservation of the machine before a long period of disuse

- Disconnect the machine from the power supply.
- Clean the machine thoroughly.
- Protect the machine from atmospheric agents, dust and dirt.

10.2 Storage of the packed machine

The machine must be stored in a hygienically clean, closed, covered environment, positioned on a flat and solid surface and protected from atmospheric agents, dust and dirt.

The temperature of the environment must be between -20 and $+40^{\circ}\text{C}$, while the humidity of the environment must not exceed 90%.

10.3 Storage of the unpacked machine

When the machine has already been unpacked, in addition to the above specified conditions, it must also be raised from the ground (fastened to a suitable pallet or other secure platform) and carefully covered to protect it against humidity, dust and dirt. If the machine is wrapped in cellophane or other plastic coverings, then it is absolutely necessary to ensure that it is not hermetically sealed, in order to avoid corrosion due to condensation. If possible, preserve the original packaging.

ATTENTION! It is absolutely forbidden to store the machine outdoors!

11 HANDLING AND INSTALLING THE MACHINE

When lifting and/or moving the machine, it is absolutely necessary to respect the instructions in this section, all the safety instructions and local safety standards and regulations in force.

ATTENTION! Before starting any handling procedure, check the total weight of the machine with and without packaging and then use appropriate, correctly positioned equipment to lift the packed/unpacked machine as per the procedures specified below.

Primary equipment handling regulations:

- Ensure that the lifting device is suitable for the load to be handled.
- While moving the machine, keep it close to the ground.
- Ensure that the area across which the load is moved is clear of objects, persons and animals.
- Wear suitable, protective clothing.

ATTENTION! During the lifting procedure, the machine is in an inclined position since the centre of gravity has been shifted. However, this does not compromise the safety of the persons or of the machine itself. Avoid oscillations during this operation.

Upon delivery of the packed machine, check that the outer packaging is intact and that there are no traces of external damage to the machine. If any damage is detected, accept the goods from the carrier with reservation, as the carrier is responsible for any eventual damage to the machine during transport.

11.1 Operation A: Unpacking, lifting the machine and connecting it to the power supply

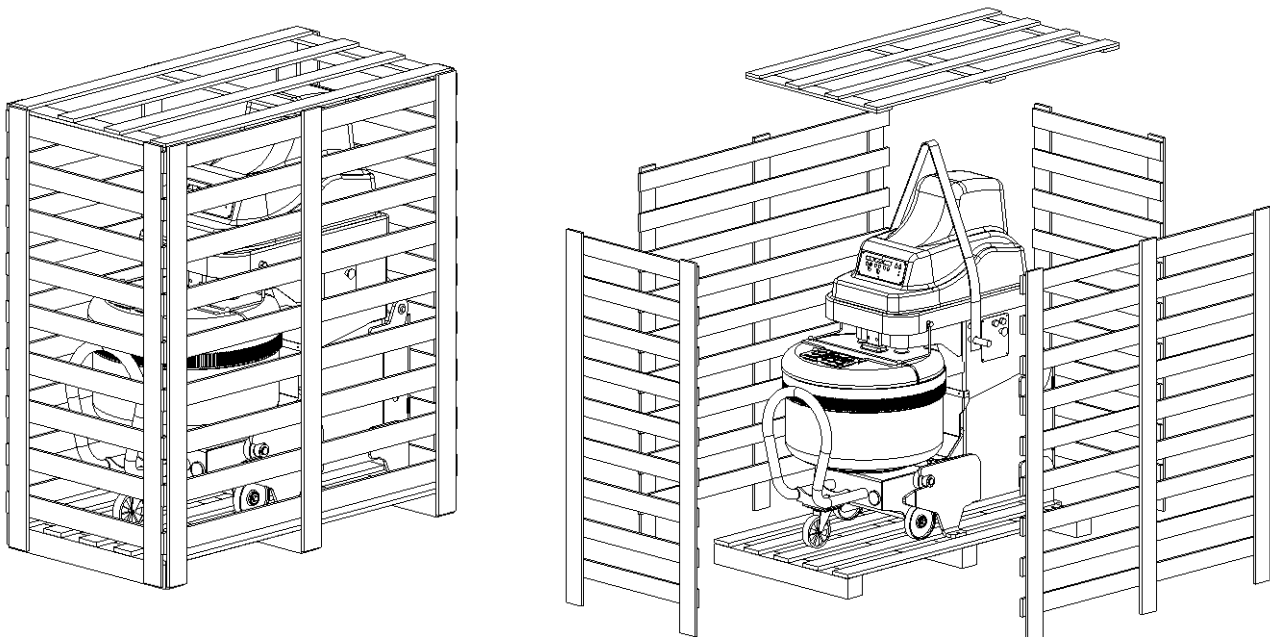

Remove the outer packing material and the screws which have been placed through the machine feet to secure the machine to the pallet during transport. Carefully select the location where the machine will be used, ensuring that:

- the floor is level and that there is sufficient space around the machine to respect the recommended minimum distances from the surrounding walls (indicated in the drawing below);
- the operator can easily load the ingredients and remove the kneaded dough;
- there is sufficient space around the machine for the cleaning and maintenance procedures.

SPIRAL MIXER MAG-R 80

Date création : 12-09-2012

Date révision :

Code : B600006AV-0002

400V - 50HZ - Tri

Version :

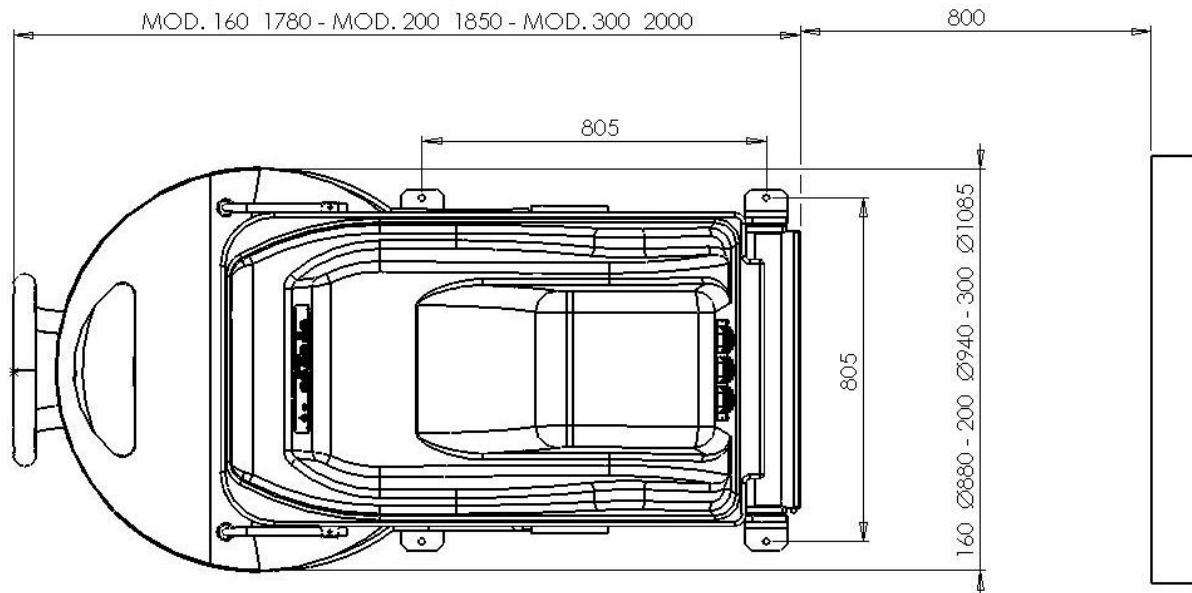
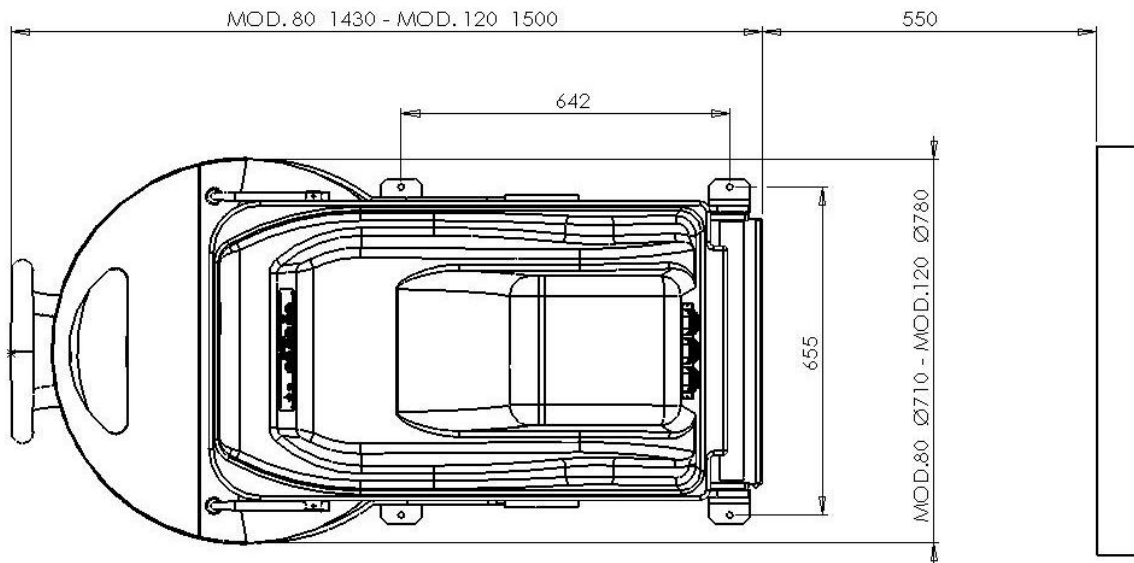

SPIRAL MIXER MAG-R 80

Date création : 12-09-2012

Date révision :

Code : B60006AV-0002

400V - 50HZ - Tri

Version :

Before carrying out any procedure, check the net and gross weight of the machine and use appropriate equipment to lift and move the machine.

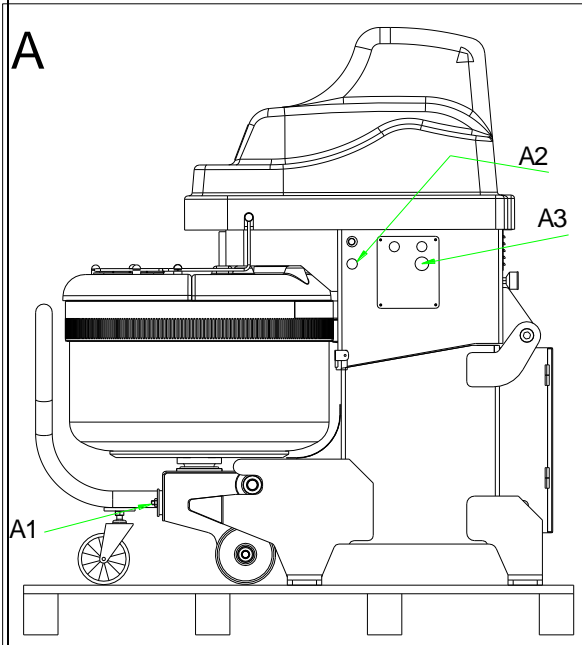

Without removing the tie rods (A1) used to fasten the bowl trolley to the machine during transport, lift the machine from the pallet (for example, by placing a suitable iron bar of diameter 30 mm and length 1100 mm through the special holes (A2) and securing the bar to a suitable belt). Position the machine in the selected location which must have a smooth, level floor sufficiently strong to allow the machine to be securely fastened to the ground. Furthermore, the machine must be positioned near to an appropriate power supply.

11.2 Connection to the power supply



Before connecting the machine to the power supply, make sure that the voltage (V), the frequency (Hz) and the number of phases of the power supply correspond to those specified on the machine serial plate and on the motor; an incorrect connection will damage the machine and will invalidate the guarantee.

After having connected the machine to the power supply, check that the direction of rotation of the spiral is correct, i.e. anticlockwise seen from the top. If the direction of rotation of the spiral is incorrect (i.e. clockwise), then it is necessary to invert the two wires from the power supply cable at the machine terminal box, in order to correct the direction of rotation. When the machine is supplied with an *electronic control panel*, then it is possible to check that the machine has been connected correctly by proceeding as follows:

- Turn on the main switch located on the electrical panel at the back of the machine;
- Press the "STOP" push button on the front control panel.

If the machine has been connected correctly, then the machine head opens.

If the machine has been connected incorrectly, then the machine head does not open and the message "Err PHAS" appears on the displays on the front control panel. In this case, it is necessary to invert the two wires from the power supply cable at the machine terminal box, in order to correct the direction of rotation; press the "STOP" button again and check that the machine head opens.

SPIRAL MIXER MAG-R 80

Date création : 12-09-2012

Date révision :

Code : B600006AV-0002

400V - 50HZ - Tri

Version :

11.3 Operation B: Levelling the machine and fastening it to the floor

ATTENTION ! In order to ensure that the machine functions properly, it is necessary to correctly adjust the level of the bowl trolley with respect to the floor. This procedure is described in the following section.

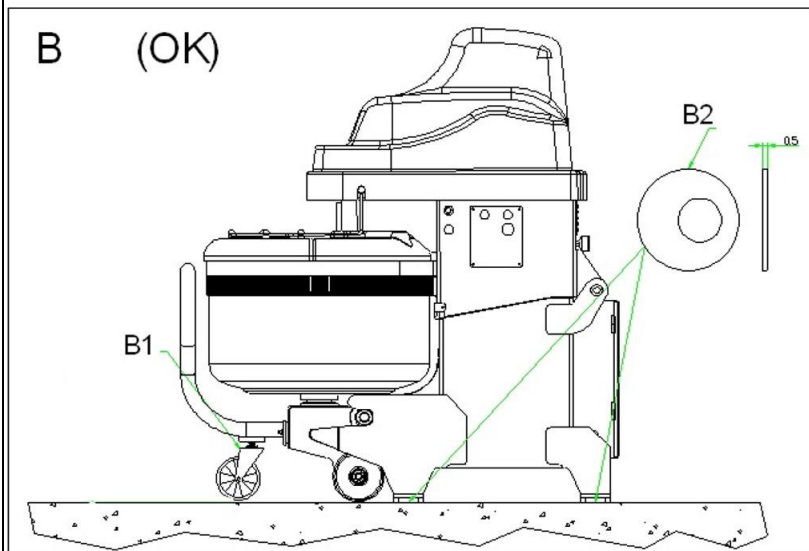

Without removing the tie rods (A1) which fasten the bowl trolley to the machine during transport, level the machine so that the revolving wheel (B1) of the bowl trolley itself just touches the floor without exerting excessive pressure. This procedure can be carried out by using the special shimming rings (B2) which must be positioned under the front feet or under the rear feet of the machine until the correct position has been found. If the adjustment is carried out correctly, then it must be possible to manually rotate wheel B1 with some resistance. These are the conditions necessary to optimise the bowl rotation and maximise the attractive force of the hooking magnet.

To fix the machine to the floor use 4 expansion inserts of diameter 10-12 mm and ensure that these pass both through the holes in the machine feet and through the corresponding shimming rings B2.

ATTENTION ! The situations illustrated below compromise the machine functions:

C1: Wheel lifted off the floor

D1: Wheel exerting too much pressure on the floor

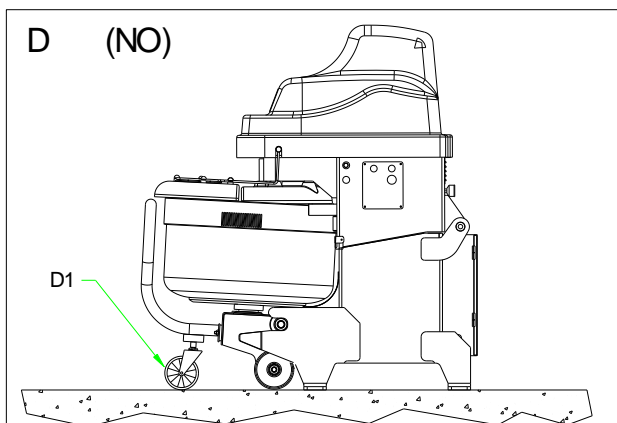
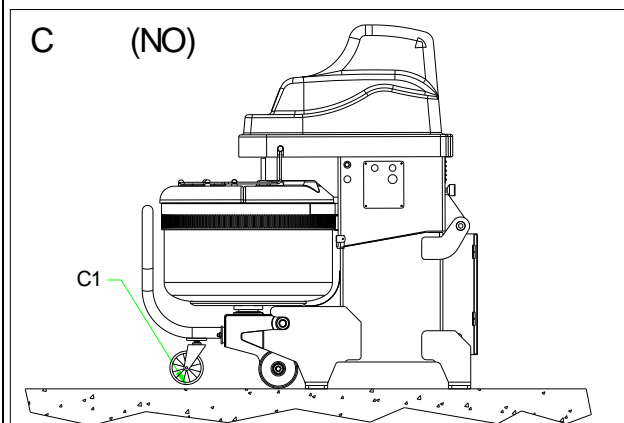

11.4 Operation C: Removing the bowl trolley from the machine

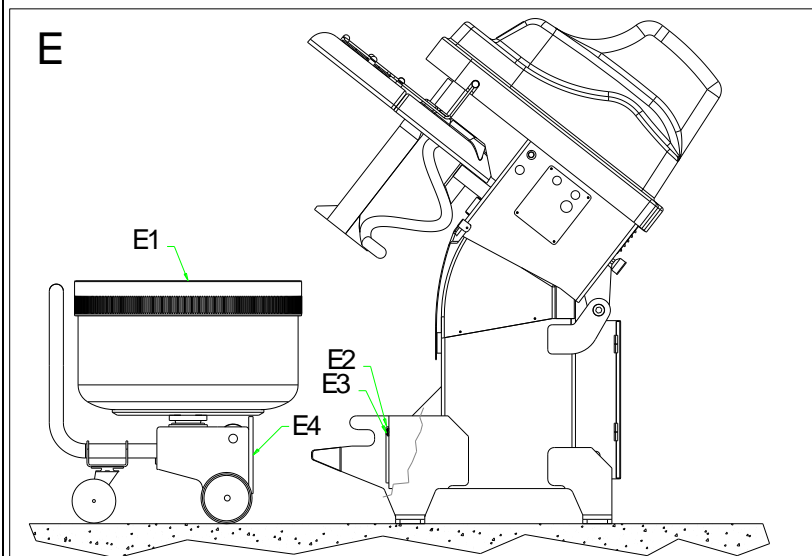

Remove the screw nuts and the tie rods used to fasten the bowl trolley to the machine during transport. Press the STOP button to open the machine head and release the bowl trolley E1. It is now possible to view the bowl trolley sensor E2, the magnet E3 and the anchor E4 which hooks the bowl trolley to the magnet.

11.5 Operation D: Inserting the bowl trolley and preparing the machine for use

Insert the bowl trolley into the machine (figure G). If the bowl trolley is correctly positioned, then the sensor (E2) signals the presence of the bowl trolley and the machine head can be closed by pressing the Head Down button (G1) located on the control panel on the right and on the left side of the machine.

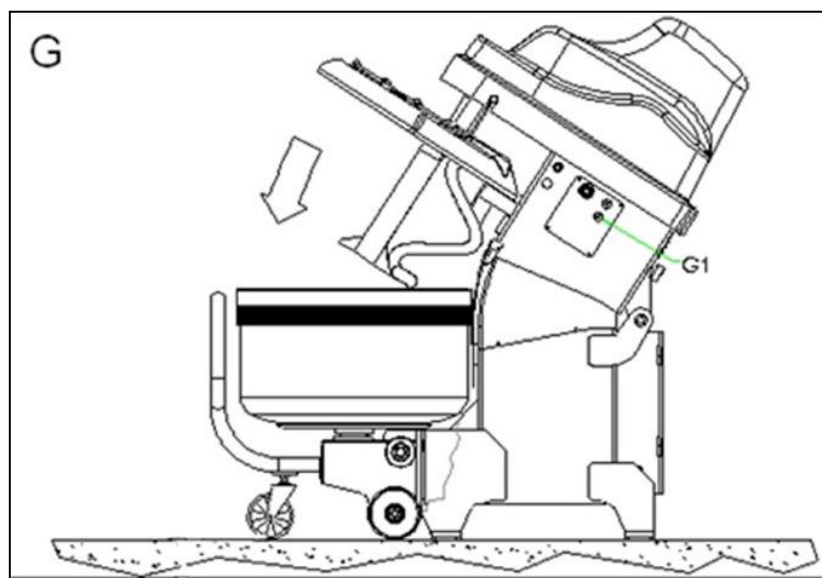

The Head Down button activates the magnet which holds the bowl trolley in place and lowers the machine head. For safety reasons, the head moves only while the button is kept pressed in, therefore, if the button is released the head stops in an intermediate position.

Press the **Head Down button G1** until the machine head is completely closed. The machine is now ready for use.

It is recommended that the operator carry out the bowl trolley insertion and removal procedures several times to become familiar with these operations.

SPIRAL MIXER MAG-R 80

Date création : 12-09-2012

Date révision :

Code : B600006AV-0002

400V - 50HZ - Tri

Version :

11.6 General Operating conditions

Environmental conditions: The machine must be installed on a solid and level surface, inside a well lit and ventilated building.

The temperature of the environment must be between 5 and 40°C and the humidity of the environment must not exceed 90%.

Illumination: The light available for the person operating on the machine must be suitable for the type of task being executed, according to current legislation. The lighting must be sufficient to clearly read the machine controls and warning/danger signs, without blinding the operator.

Vibrations: If the machine is used correctly, then the vibrations present during the operation of the machine do not constitute any type of danger.

Electromagnetic interference: The machine referred to in this manual has been designed to operate correctly in an industrial type of electromagnetic environment.

Cleanliness of the work environment: The machine may only be used in environments suitable for the storage and production of food products. Furthermore, it is necessary to respect the following operating conditions:

- The absence of ventilation while loading the ingredients and during the initial phase of the work cycle (amalgamation of the ingredients), to prevent excessive food powder emissions.
- The use of containers and tools which are suitable for handling food products.

12 CLEANING THE MACHINE

The machine has been designed for the production of food products and, therefore, it is indispensable that it be thoroughly cleaned and sanitised every day, as per local sanitation requirements for food production environments. Furthermore, the first and most efficient form of preventive maintenance is keeping the machine clean; regular and thorough cleaning prevents the build-up of dough residue which, in the long term can damage the moving members. The mixer structure, thanks to the easy-to-clean surfaces and the possibility of opening and blocking the machine head and removing the bowl trolley, simplifies the cleaning procedures.

12.1 Cleaning the body of the machine

It must only be cleaned using a damp cloth which has been soaked in water and sufficiently wrung out. The cloth must be selected and sanitised as specified by local sanitation requirements for food production environments. It is absolutely forbidden to use cleaning tools which can scratch or damage the machine.

12.2 Cleaning the inside of the bowl and the mixing tools

Remove all dough residue using a suitable tool which will not scratch or damage the internal surface of the bowl and the mixing tools. Use water and, if necessary, a food grade soap, to clean the bowl. Rinse the bowl thoroughly. Sanitise the bowl as specified by local sanitation requirements for food production environments.

13 OPERATING PROCEDURES



ATTENTION! Strict observance of the safety procedures specified in this manual and of the local safety standards and regulations is indispensable when carrying out any operation on the machine.

13.1 Preliminary machine check-up

Before starting the work cycle, check that:

- the machine is in a stable position on a flat, smooth and solid surface;
- the machine has been correctly connected to the power supply;
- the machine parts are clean.

13.2 Loading the ingredients to be kneaded

The ingredients can be loaded into the bowl with the bowl trolley inserted into the machine or with the bowl trolley removed from the machine.

Bowl trolley removed from the machine:

Check that there are no foreign objects in the bowl and that the bowl is clean.

Load the water and then the flour into the bowl, respecting the maximum quantities allowed for the specific machine (Appendix 2).

Insert the bowl trolley correctly into the machine, lower the machine head and ensure that the mobile bowl cover is closed.

Bowl trolley inserted into the machine:

With the machine turned off and the bowl trolley correctly inserted into the machine, it is possible to gain access to the bowl simply by lifting the protective, mobile bowl cover.

Check that there are no foreign objects in the bowl and that the bowl is clean.

Load the water and then the flour into the bowl, respecting the maximum quantities allowed for the specific machine (Appendix 2).

Recommended sequence for loading the ingredients:

1. Pour the required quantity of water into the bowl.
2. Pour the flour into the bowl (in the correct proportion with respect to the water).
3. Subsequently, add the other ingredients for the dough (exclusively those suitable and allowed for the production of bread and confectionery products, e.g. salt, leavening agent, butter, margarine etc.), by lifting the mobile protective bowl cover and pouring them into the bowl. If the mobile bowl cover is lifted while the machine is operating, then the machine will stop; it is therefore necessary to close the mobile bowl cover and restart the machine to complete the work cycle by pressing the required start button. Small quantities of ingredients can be added to the dough by pouring them directly through the opening/s in the mobile bowl cover, without opening the cover itself.

The operator is strongly advised against loading the flour into the bowl before the water as this creates high density lumps in the dough which cause the machine to function irregularly, thus leading to sudden increases in power which reduce the life of the transmission belts and wear and tear parts in general.

SPIRAL MIXER MAG-R 80

Date création : 12-09-2012

Date révision :

Code : B600006AV-0002

400V - 50HZ - Tri

Version :

13.3 Executing a work cycle

It is only possible to start the machine when the bowl trolley has been correctly inserted into the machine, the machine head and the mobile bowl cover have been closed.

Appendix 1 contains a detailed description of the control panel, its functions and how to program and execute a work cycle.

All the machine commands required to carry out a work cycle are located on the front control panel.

- The Start button starts the set work cycle.
- The time countdown of the work cycle being executed is displayed on the control panel on a digital display or by means of LEDS (depending on the type of control panel).
- If the mobile protective bowl cover is opened, then the work cycle is interrupted; to resume the work cycle, press the Start button again.
- The Emergency button stops and resets the work cycle; the time display returns to the initial setting of the last work cycle executed.

13.4 Warnings relative to repeated interruptions of a work cycle

Once the work cycle has been started by pressing the Start button, the machine continues to knead the dough until the set work time has elapsed, unless the operator interrupts the work cycle. Avoid repeated interruptions of the work cycle as this leads to the overheating of the motor which, in the long term, can compromise the efficiency of the machine itself.

13.5 Stopping the machine

The timers automatically stop the work cycle and hence, the machine, once the programmed time has elapsed. The machine can be stopped at any time by pressing the Emergency/STOP button, however, it is strongly recommended that the operator avoid repeated interruptions of the work cycle. To switch off the machine, turn the main switch to the "O" position.

13.6 Unloading the kneaded dough

Upon completion of the work cycle, the machine head opens automatically and the bowl trolley is released. This permits the bowl trolley to be removed from the machine in order to extract the dough from the bowl. It is strictly prohibited to use any utensil which can scratch or damage the bowl and the mixing tools.

14 PERIODICAL INSPECTIONS, CLEANING AND MAINTENANCE OF THE MACHINE



ATTENTION! Before carrying out any operation related to periodical inspections, cleaning or maintenance procedures, switch off the machine by turning the main switch to the “O” position and disconnect the machine from the power supply ensuring that the electrical panel on the machine and the machine power cable are isolated from the main power supply in a safe manner for the entire duration of the intervention, without accidental risk of re-energising of the power supply.

14.1 Cleaning procedures and periodical inspections

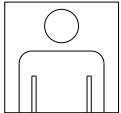

The first and most efficient form of preventive maintenance is keeping the machine clean; regular and thorough cleaning prevents the buildup of dough residue which, in the long term can damage the moving members.



Before carrying out any inspection or cleaning procedure, the operator must:

- wear protective clothing suitable for the task to be carried out; clothing which must offer protection against organic, chemical, biological, mechanical and/or electrical risks
- switch off the machine and disconnect it from the power supply.

Daily cleaning procedures and inspections:

- Clean the bowl, spiral tool, breaking column and fixed and mobile protective bowl covers, as described in the section *Cleaning the Machine*.
- Visually check that the machine and external safety devices (described in the section *Safety Instructions*) function correctly.

14.2 Inspection of the safety devices



The safety devices installed on the machine need to be inspected periodically.

Legend of the frequency of an inspection (FREQUENCY)	Legend of the manner in which an inspection must be carried out (MANNER)
d = daily w = weekly m = monthly a = annually	O = <u>Observation</u> : visual inspection (e.g. check that alarm lights/LEDS function correctly) E = <u>Execution</u> : an action is required to check the response (e.g. when the Emergency button is pressed, the machine must stop) M = <u>Measurement</u> : the inspection requires instrumentation to measure values that need to be checked (e.g. grounding values).

Main switch

Purpose: interruption of the power supply.

Function: This component disconnects the machine from the power supply. Turn it to the various positions and check that it functions correctly in each position. Turn off the main switch and check that there is no current downstream of the component.

Inspection	
Frequency	Manner
a	E

Lights on the control panel

Purpose: display of the machine status.

Different functions on the machine have a corresponding light which comes on when the function is activated. The lights are not necessary for the machine functions, however, they indicate the status of the machine (i.e what task is being executed) and therefore have an important role in the safe use of the machine.

Activate each machine function and check that the corresponding light comes on.

Inspection	
Frequency	Manner
m	O

SPIRAL MIXER MAG-R 80

Date création : 12-09-2012

Date révision :

Code : B600006AV-0002

400V - 50HZ - Tri

Version :

Stop-Emergency Circuit

Purpose: Disactivation of all the machine functions.

By pressing the red, mushroom-head Stop-Emergency push button the power supply to all the electrical machine components is interrupted and, therefore, all the machine functions are disactivated. The machine function being executed stops in the position it has reached at the time of the interruption, except for those parts subject to inertia (e.g. the spiral tool). To restart the machine, the Stop-Emergency push button must be rotated clockwise until it is unblocked.

Check that the Stop-Emergency push button functions in the above described manner.

Inspection	
Frequency	Manner
m	E

Electrical panel automation

It is necessary to periodically check the machine automation and grounding. The following components must be checked: motor protectors, electrical motors, connectors between control panel and electrical panel, grounding. Switch on the machine and check the behaviour of the described components (first with the machine operating in manual mode and then with the machine operating in automatic mode).

Inspection	
Frequency	Manner
a	E, M

SPIRAL MIXER MAG-R 80

Date création : 12-09-2012

Date révision :

Code : B60006AV-0002

400V - 50HZ - Tri

Version :

14.3 WEEKLY, MONTHLY, ANNUAL Maintenance procedures

WEEKLY MAINTENANCE:

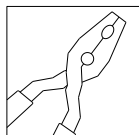

- Clean the machine thoroughly.
- Check that the operating controls and external emergency devices (Stop-Emergency button and protective mobile bowl cover) function correctly.
- Check the external components of the machine: spiral tool, breaking column, bowl.

MONTHLY MAINTENANCE:

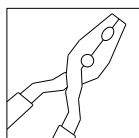

- Lubricate the bearings, if necessary.
- Check the tension of the belts.
- Check the transmissions for irregular noises.
- Check the tightness of the spiral and breaking column bolts (refer to the table of bolt tightening torques below).
- Check the efficiency of the gas struts, for models using these components to control the opening of the mobile bowl cover, and replace them if necessary.

ANNUAL MAINTENANCE:



- Check the electrical system.

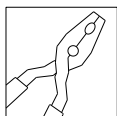

- Clean the machine and check it thoroughly (both externally and that it functions correctly).
- Thoroughly check the transmission members.
 - The transmission belts must be replaced when they start to fray or when under excessive tension, *before* they actually break. It is necessary to replace the entire set of belts relative to a transmission, even if only one of the belts requires replacement.
 - The bearings are subject to wear, especially under the following conditions: poor cleaning procedures, excessive use of the machine in first speed in the reverse direction, poor use of the machine which can lead to food products being deposited inside the group of bearings therefore reducing the life of the bearings themselves. The replacement of the bearings must be carried out by a suitably qualified technician using appropriate equipment and in full observance of the safety measures and local safety regulations.
 - Check the tightness of the bolts on the entire machine.



Indicative Bolt tightening torques

	Filet / Nominal Size thread					
	M6	M8	M10	M12	M14	M16
Tightening for Bolts (8.8) [Nm]:	9.7	23	47	80	130	196
Tightening for Bolts (10.9) [Nm]:	13.6	33	64	113	180	275
Tightening for Stainless steel Bolts [Nm]:	6	16	32	56	-	135

14.4 Adjustment of the belt tension and replacement of the transmission belts

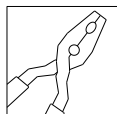

The tension of the transmission belts must be adjusted when the rotation of the spiral tool/bowl slows down or is not smooth during the execution of a work cycle.

It is obligatory to:



- wear protective clothing suitable for the task to be carried out,
- switch off the machine and disconnect it from the power supply, before carrying out any operation on the machine.

The procedure for the adjustment of the belt tension and replacement of the transmission belts is described in Appendix 3.

Note: Before replacing the belts, ensure that the new belts have the same characteristics as the original belts installed on the machine by the manufacturer.

15 TROUBLE SHOOTING

PROBLEM	POSSIBLE CAUSES	SOLUTION	
When the main switch is turned to the "I" position, the lights on the control panel do not come on	1) The machine has been connected incorrectly. 2) The plug has not been inserted correctly into the socket. 3) There is a disconnected wire in the plug. 4) There is a burnt control panel light. 5) The Emergency button has not been released.	1,2,3) Check the electrical connection. 4) Replace the light bulb. 5) Release the Emergency button, by rotating it clockwise.	
When the Start button is pressed, the machine does not start	1) The mobile bowl cover is open. 2) There is a fault in the safety microswitches.	1) Close the mobile bowl cover. 2) Replace the microswitches.	
Continuous noise..	1) The bearings are no longer efficient.	1) Check and, if necessary, replace the bearings.	
The spiral tool stops..	1) The transmission belts are loose. 2) The transmission belts are worn.	1) Tighten the belts. 2) Replace the belts.	
The bowl stops.	1) The transmission belts are loose. 2) The transmission belts are worn.	1) Tighten the belts. 2) Replace the belts.	

16 DISASSEMBLING AND DISPOSING OF THE MACHINE

16.1 Main components

- Primary materials: Cast iron, steel, stainless steel, bronze, copper, aluminium, rubber, plastic (eg. PET, ABS, PST, polyurethane).
- Surface treatments: Painting (for metallic surfaces); pickling, polishing, satin finishing (for stainless steel parts).
- Forming processes: Rolling and drawing of steel profiles, welding, machining.

16.2 Disassembly and disposal of the machine

- The buyer is directly responsible for putting the machine out of service.
- The disassembly of mechanical and electrical components must be assigned to competent persons.
- The machine must be disposed of according to local standards and regulations. In any case:
 - Clean the machine thoroughly.
 - Assign the disposal of the electrical panel to a suitably specialised company.

17 OPERATING MODES FOR CONTROL PANEL

ATTENTION!

The manufacturer reserves the right to modify its machine models as deemed necessary to improve the product. Therefore, when requesting technical assistance and spare parts, always specify:

- The model and type of machine;
- The serial number;
- The year of construction;
- The position, description, part number and quantity of the spare parts required.

For additional information on the machine operation, contact the manufacturer.

ATTENTION!

The manufacturer reserves the right to modify its machine models as deemed necessary to improve the product. Therefore, when requesting technical assistance and spare parts, always specify:

- The model and type of machine;
- The serial number;
- The year of construction;
- The position, description, part number and quantity of the spare parts required.

For additional information on the machine operation, contact the manufacturer.

The controls for the various functions required are located on the front and side control panels. In particular:

- the front control panel contains all the controls required for the dough mixing functions, while
- the identical left-hand side and right-hand side control panels contain only the controls for the mixer head movements

The specific function of each pushbutton and selector is indicated by a symbol or drawing on or near each control.

17.1 front control panel for dough mixing functions

The figure shows the control panel for the dough kneading functions in the two-speed model, which is located on the front of the mixer head cover. The first speed (scale 0-10) and second speed (scale 0-20) dials are incorporated into a single timer with a base measuring 72x144 mm.



DESCRIPTION OF THE MIXER PUSH BUTTON CONTROL PANEL



BOWL ROTATION SELECTOR

Selects the direction of rotation of the bowl in the timer-controlled operating mode in first speed.

In the anticlockwise direction, the bowl rotates in the same direction as the spiral. In the clockwise direction, the bowl rotates in the opposite direction to the spiral.

It serves to accelerate the amalgamation of the ingredients.

N.B. The reverse (clockwise) bowl rotation function can only be used for a maximum time of 1 minute; the reason being that, after the dough has reached a certain consistency, it starts beating against the breaking column which can, with time, damage the breaking column itself and, in addition, place the machine under excessive stress



START BUTTON

This push button is used to start mixing the ingredients at the speed selected according to the timer settings. (Refer to the section on the mixer operating modes).

In the timer-controlled mode in first speed, the bowl rotation direction is selected using the *Bowl rotation selector*. In second speed the bowl rotation direction is always anticlockwise.



WORK CYCLE MODE SELECTOR

TIMER-CONTROLLED MODE:

To permit the machine to function using the timers, it is



necessary to turn this selector to the clock symbol.

In this mode, it is possible to work in automatic mode, semi-automatic mode or in manual mode. In first speed, it is possible to select the direction of rotation of the bowl (clockwise or anticlockwise) using the *Bowl rotation selector*.

MANUAL MODE – 1st speed –

bowl rotation anticlockwise:

To permit the machine to function in manual mode in first speed (slow), it is necessary to turn this selector to the symbol I ,



In this mode the timer is disabled and the bowl only rotates in the anticlockwise direction.

MANUAL MODE – 2nd speed

bowl rotation anticlockwise:

To permit the machine to function in manual mode in second speed (fast), it is necessary to turn this selector to the symbol II



In this mode the timer is disabled and the bowl only rotates in the anticlockwise direction.

Note: For more detailed instructions, refer to the section "Operating modes"

DESCRIPTION OF THE MIXER PUSH BUTTON CONTROL PANEL (CONT.)



STOP BUTTON

The rotation of the bowl and of the spiral tool can be stopped by pressing the STOP button.
To restart the machine, press the start button.
The timers are reset.

17.2 Left- and right-hand side control panels for mixer head movements



- EMERGENCY PUSHBUTTON

- "HEAD-UP" PUSHBUTTON

This button is used to manually raise the mixer head when the mixing cycle has been stopped manually by pressing the EMERGENCY button. Once the mixer head is completely open, the bowl trolley is released and it is possible to remove it from the mixer for the subsequent extraction of the dough.

This button is not active when a mixing cycle is being executed

- "HEAD DOWN" PUSHBUTTON:

Closes the mixer head, provided the bowl trolley has been correctly positioned in the mixer. Once the mixer head is completely closed, the "Head Down" button lights up, indicating that the machine is ready for use and it is possible to start a new kneading cycle

Note:

- For safety reasons, the "Head Up" and "Head Down" pushbuttons are only active when these buttons are kept pressed in.

USE OF THE "HEAD DOWN" PUSHBUTTON

After having correctly positioned the bowl with all the ingredients into the machine, press the "Head Down" pushbutton located on the control panel to close the machine head. If the bowl has not been correctly positioned, then the head will not come down and it is necessary to reposition the bowl trolley. Keep the Head Down pushbutton pressed in until the machine head is completely closed. At this point, the "Head Down" button lights up, indicating that the machine is ready for use.

Note:

- The magnet holding the bowl trolley to the mixer is active only while the "Head Down" button is kept pressed in. Therefore, if this button is released before the mixer head is completely closed, then the magnet is de-activated and the bowl trolley released; it is thus extremely important that the ground be level to ensure that the bowl trolley remains in position.

SPIRAL MIXER MAG-R 80

Date création : 12-09-2012

Date révision :

Code : B60006AV-0002

400V - 50HZ - Tri

Version :

17.3 timer-controlled OPERATING MODES

The mixer can run in three modes, when the mobile bowl cover is closed:

- Manual mode;
- Semi-automatic mode;
- Automatic mode.

These operating modes are selected using the special timer composed of a first speed dial (low speed - located to the left) which has a scale of 0-10 minutes and a second speed dial (high speed -located to the right) which has a scale of 0-20 minutes.

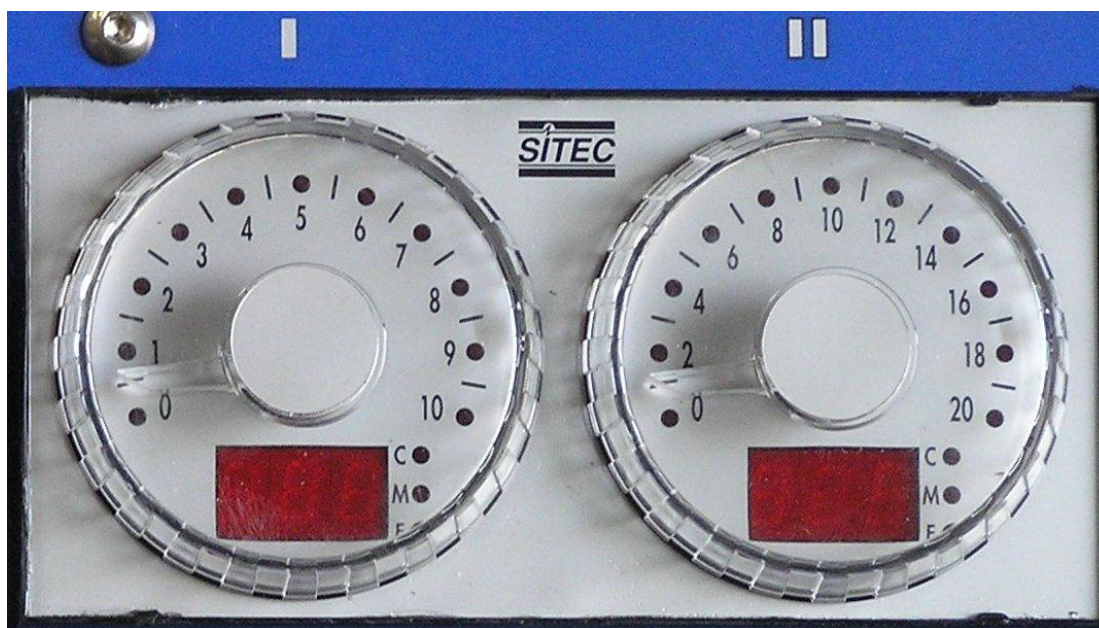

Each timer has three settings:

- Count (C):
If the timer dial is set above the 0 marking, then the LED corresponding to this setting lights up and flashes when the START button is pressed and the time countdown begins. In this setting the machine works for the time set and in the speed corresponding to the specific dial (first speed for the left dial and second speed for the right dial)
- Manual (M):
If the timer dial is set below the 0 marking, then the LED corresponding to this setting lights up. In this setting the machine works in manual mode, i.e. in the speed corresponding to the specific dial until the STOP button is pressed to stop the work cycle.
- Excluded (E):
If the timer dial is set on the 0 marking, then the LED corresponding to this setting lights up. In this setting the timer is switched off and it is not possible to work in the speed corresponding to this dial.

SPIRAL MIXER MAG-R 80

Date création : 12-09-2012

Date révision :

Code : B600006AV-0002

400V - 50HZ - Tri

Version :

Manual Mode

To work in manual mode in first speed:



- Set the “Work Cycle Mode Selector” to the clock symbol.
- Set the left (first speed) dial below the zero marking until the “Manual” LED on this timer lights up.
- Press the START button on the control panel to start running in first speed, in order to amalgamate and pre-mix the ingredients.
It is possible to select the reverse bowl rotation direction using the BOWL ROTATION SELECTOR, to accelerate the amalgamation of the ingredients. Before changing the bowl rotation direction, wait 1 second with the selector in the central position, in order to stop the rotation
- Press the STOP button to end the manual cycle in first speed.
- Press in the “HEAD UP” button to raise the mixer head. When the mixer head is completely open, the bowl trolley is released.

SPIRAL MIXER MAG-R 80

Date création : 12-09-2012

Date révision :

Code : B600006AV-0002

400V - 50HZ - Tri

Version :

To work in manual mode in second speed:



- Set the “Work Cycle Mode Selector” to the clock symbol.
- Set the left (first speed) dial on the zero marking until the “Excluded” LED on this dial lights up.
- Set the right (second speed) dial below the zero marking until the “Manual” LED on this timer lights up.
- Press the START button on the control panel to start running in second speed, in order to complete the kneading process.
The bowl rotation direction is anticlockwise, in the same direction of rotation as the spiral.
- Press the STOP button to end the manual cycle in second speed.
- Press in the “HEAD UP” button to raise the mixer head. When the mixer head is completely open, the bowl trolley is released.

Semi-automatic Mode

To work in semi-automatic mode in first speed:



- Set the “Work Cycle Mode Selector” to the clock symbol
- Set the left (first speed) dial to the required mixing time.
- Set the right (second speed) dial on the zero marking until the “Excluded” LED on this dial lights up.
- Press the START button on the control panel to start running in first speed, in order to amalgamate and pre-mix the ingredients. The “Count” LED on the first speed dial lights up and starts to flash. It is possible to select the reverse bowl rotation direction using the BOWL ROTATION SELECTOR, to accelerate the amalgamation of the ingredients. Before changing the bowl rotation direction, wait 1 second with the selector in the central position, in order to stop the rotation.
- When the time set on the first speed dial has elapsed: the mixer automatically stops, the mixer head automatically opens and when it is completely open, the bowl trolley is released.

To work in semi-automatic mode in second speed:



- Set the “Work Cycle Mode Selector” to the clock symbol
- Set the left (first speed) dial on the zero marking until the “Excluded” LED on this dial lights up.
- Set the right (second speed) dial to the required mixing time.
- Press the START button on the control panel to start running in second speed, in order to complete the mixing process. The “Count” LED on the second speed dial lights up and starts to flash. The bowl rotation direction is anticlockwise, in the same direction of rotation as the spiral.
- When the time set on the second speed dial has elapsed: the mixer automatically stops, the mixer head automatically opens and when it is completely open, the bowl trolley is released.

SPIRAL MIXER MAG-R 80

Date création : 12-09-2012

Date révision :

Code : B600006AV-0002

400V - 50HZ - Tri



Version :

Automatic Mode



- Set the “Work Cycle Mode Selector” to the clock symbol.
- Set the left (first speed) dial to the required mixing time.
- Set the right (second speed) dial to the required mixing time.
- Press the START button on the control panel to start running in first speed, in order to amalgamate and pre-mix the ingredients. The “Count” LED on the first speed dial lights up and starts to flash. It is possible to select the reverse bowl rotation direction using the BOWL ROTATION SELECTOR, to accelerate the amalgamation of the ingredients. Before changing the bowl rotation direction, wait 1 second with the selector in the central position, in order to stop the rotation. When the time set on the first speed dial has elapsed, the mixer automatically starts running in second speed. At this point the “Count” LED on the second speed dial light up and starts to flash.
- When the time set on the second speed dial has elapsed, then the mixer automatically stops, the mixer head automatically opens and when it is completely open, the bowl trolley is released.

17.4 manual OPERATING

MODES  and 

It is possible to exclude the timer and work in manual mode by positioning the WORK CYCLE MODE SELECTOR on the symbol:



to work in **manual mode in first speed**. In this mode the bowl only rotates in the anticlockwise direction (the same direction as the spiral) it is not possible to reverse the bowl rotation direction.

OR



to work in **manual mode in second speed**. In this mode the bowl only rotates in the anticlockwise direction (the same direction as the spiral).

SPIRAL MIXER MAG-R 80

Date création : 12-09-2012

Date révision :

Code : B600006AV-0002

400V - 50HZ - Tri

Version :

The manual work cycle is started by pressing the START BUTTON and stopped by pressing the STOP BUTTON. At the end of the kneading cycle the mixer head is raised by pressing the HEAD UP BUTTON. When the mixer head is completely open, the bowl trolley is released

17.5 General Remarks

- If the mobile protective bowl cover is opened while a mixing cycle is being carried out, then the machine will stop and the timer will not be reset but will maintain the time reached. To restart the mixer and resume the work cycle, it is necessary to close the mobile bowl cover and press the START button.
- It is only possible to reverse the bowl rotation (using the BOWL ROTATION SELECTOR) in first speed in the timer-controlled operating mode (clock symbol); this function is automatically disabled when the machine is running in second speed or when one of the manual operating modes is selected using the work cycle mode selector (symbol I or symbol II).
N.B. The reverse (clockwise) bowl rotation function can only be used for a maximum time of 1 minute; the reason being that, after the dough has reached a certain consistency, it starts beating against the breaking column which can, with time, damage the breaking column itself and, in addition, place the machine under excessive stress
- In automatic mode, when the time set for the first speed cycle has elapsed and the bowl rotation direction is reverse (i.e. in the clockwise direction, opposite to the direction of rotation of the spiral), then the bowls stops for approximately 1,5 seconds, before the machine switches to the second speed (where the number of revolutions of the spiral increases and the bowl rotates in the same direction as the spiral). This pause is necessary to allow the bowl rotation direction to be changed and to avoid sudden changes in the direction of rotation of the bowl motor, which in the long term, will damage the motor and hence the machine itself.

18 SPECIAL MAINTENANCE PROCEDURES

Any type of intervention on the machine must be carried out by suitably qualified personnel, using suitable equipment and in accordance with the local safety standards and regulations in force!

It is obligatory to:

- wear protective clothing suitable for the task to be carried out,
- switch off the machine and remove the plug from its socket, before carrying out any operation on the machine.

LUBRICATION

There is one lubrication circuit, for the spiral bearings. The lubrication element is located in the back of the machine.

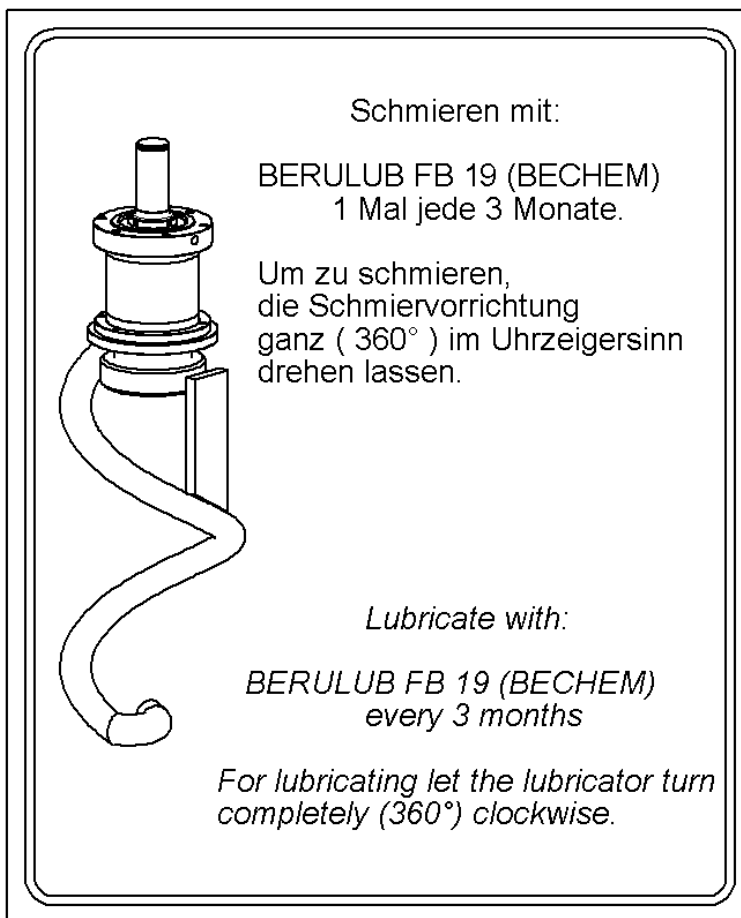

19 EXTRAORDINARY MAINTENANCE



Any type of intervention on the machine must be carried out by suitably qualified personnel, using suitable equipment and in accordance with the local safety standards and regulations in force!

It is obligatory to:

- wear protective clothing suitable for the task to be carried out,
- switch off the machine and remove the plug from its socket, before carrying out any operation on the machine.

19.1 Adjustment of the bowl friction wheels

The central bowl guide assembly is composed of two bowl friction wheels. Their position has been perfectly adjusted during the machine assembly and testing phases.

However, should it be necessary to adjust the position of the bowl friction wheels on the bowl rim, proceed in the following manner:

- with the machine head completely open, remove one of the side panels on the machine, to gain access to the thrust roller assembly;
- loosen the two fastening screws on the upper support of the shaft of the bowl friction wheels;
- loosen the two fastening screws on the lower support of the shaft of the bowl friction wheels;
- move the upper bowl friction wheel forwards or backwards, as required, by using the corresponding adjustment screw which moves the upper support ;
- move the lower bowl friction wheel forwards or backwards, as required, by using the corresponding adjustment screw which moves the lower support ;
- fasten the two upper and two lower screws of the corresponding upper and lower supports.

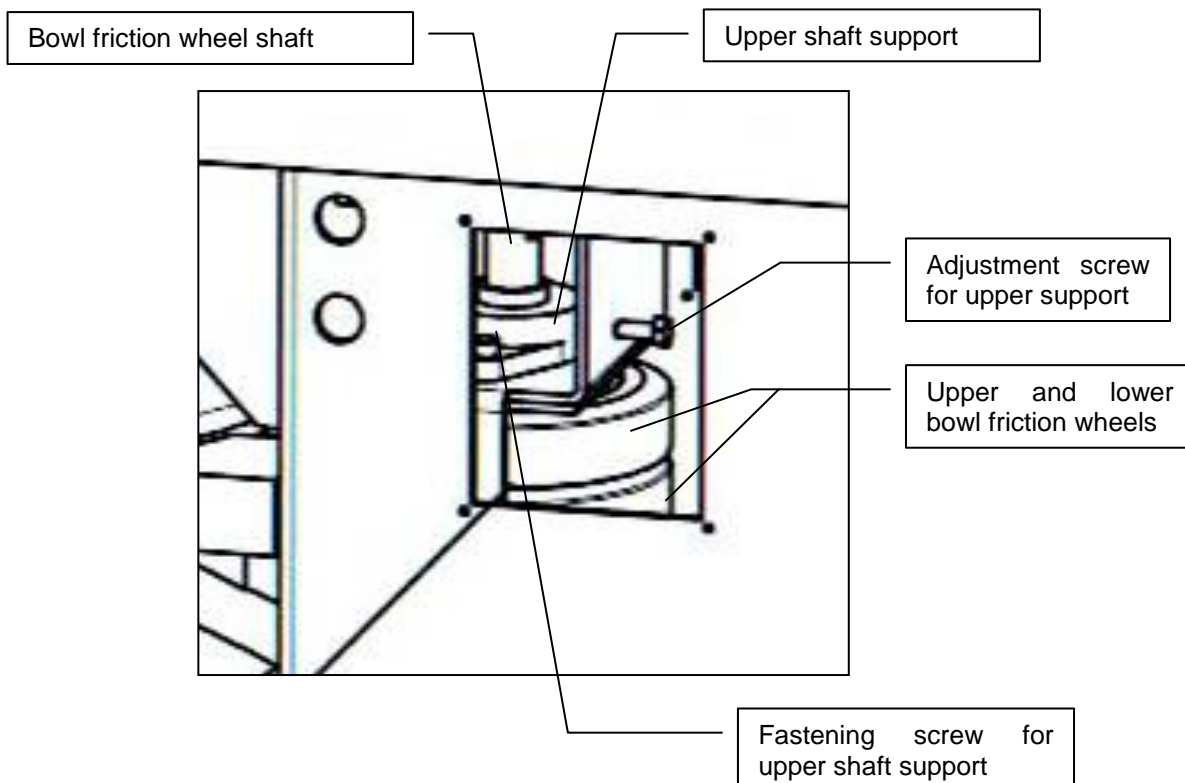

19.2 Maintenance of the upper transmission elements

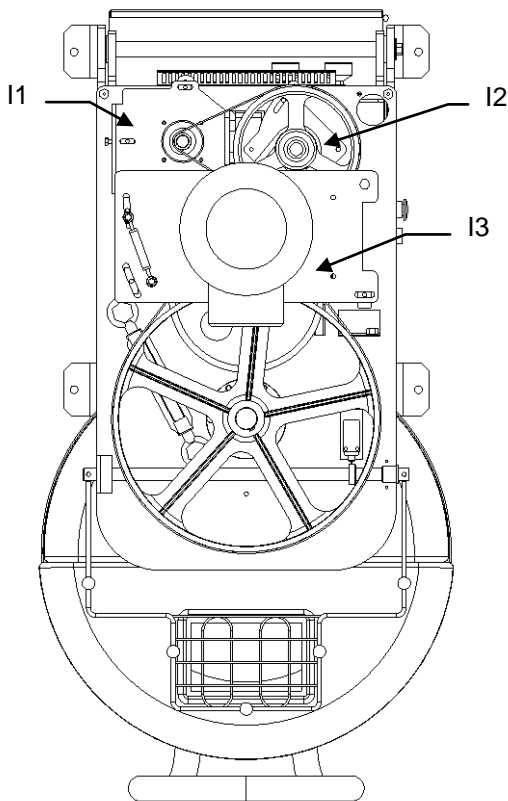

To gain access to the upper transmission elements, proceed in the following manner:

- Loosen and remove the four lateral screws which fasten the head cover to the machine body and carefully lift the head cover without removing it completely;
- Disconnect the front control panel on the head cover from the rear electrical panel by disconnecting the connector from the multiple socket located on the motor plate.
- It is now possible to remove the head cover from the machine structure, thus allowing full access to the spiral and bowl transmission elements.

To adjust the chain, loosen the bolts which fasten the support I2 to the base of the machine head. At this point use the tensioners to correct the chain tension, then fasten the bolts of the support.

To adjust the tension of the Poly-V belt of the bowl transmission, loosen the bolts of the support I1 and use the adjusting bolts to correct the belt tension, then fasten the bolts of the support.

To adjust the tension of the Poly-V belt of the spiral transmission, loosen the bolts of the support I3. At this point use the tensioner to correct the belt tension, then fasten the bolts of the support.

N.B. When adjusting the chain tension, inevitably, the tension of the Poly-V bowl transmission belt is also varied. Therefore, after having adjusted the chain tension, it is always necessary to check and, if necessary, adjust the tension of the bowl transmission belt.

19.3 Maintenance of the hydraulic unit and fan in the machine base

In order to gain access to the elements in the machine base, it is necessary to proceed in the following manner:

- remove the cover of the electrical panel at the back of the machine;
- loosen and remove the central upper screw which fastens the electrical unit to the back of the machine and carefully tilt the electrical unit backwards, resting it on the floor;
- it is now possible to access the hydraulic unit and the fan.

19.4 Access to the hydraulic head cylinder and hook

Access to the bottom of the hydraulic head cylinder can be gained simply by loosening and lowering the rear electrical unit as described above. However, to gain access to the hook of the hydraulic head cylinder, it is necessary to proceed in the manner described below.

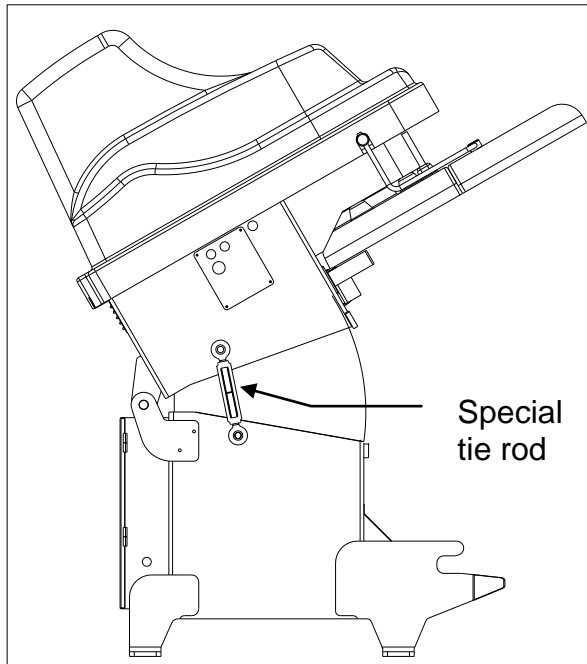

Diagram A

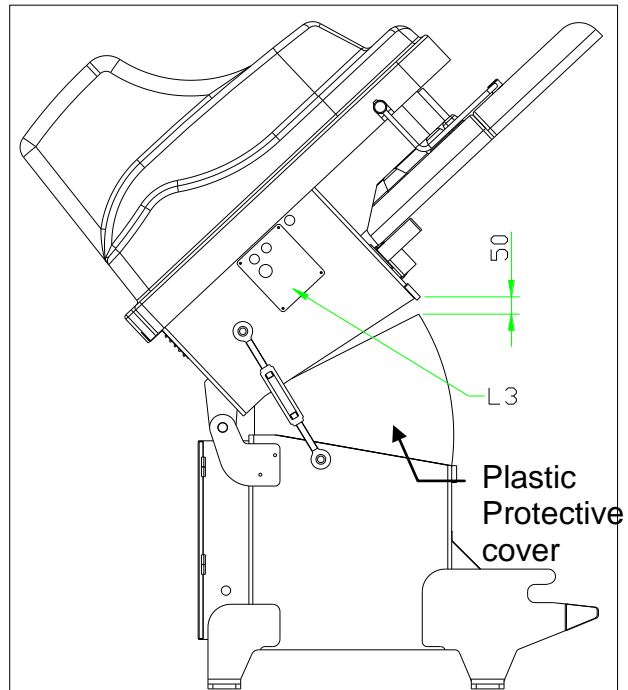

Diagram B

Note: A special tie rod, supplied with the machine and placed inside the machine bowl, must be used in the operations required to gain access to the head cylinder and hook.

- Open the machine head so as to allow the special tie rod to be fitted to the holes specifically designed for this purpose, as illustrated in Diagram A.
- Carefully remove the side control panels (L3 - Diagram B).
- Slightly tension the tie rod so that the weight of the head is completely supported by the tie rod itself.
- At this point it is possible to remove the pin which fastens the hook of the hydraulic unit to the machine head (Diagrams C and D), by removing the corresponding screws and washers.

SPIRAL MIXER MAG-R 80

Date création : 12-09-2012

Date révision :

Code : B600006AV-0002

400V - 50HZ - Tri

Version :

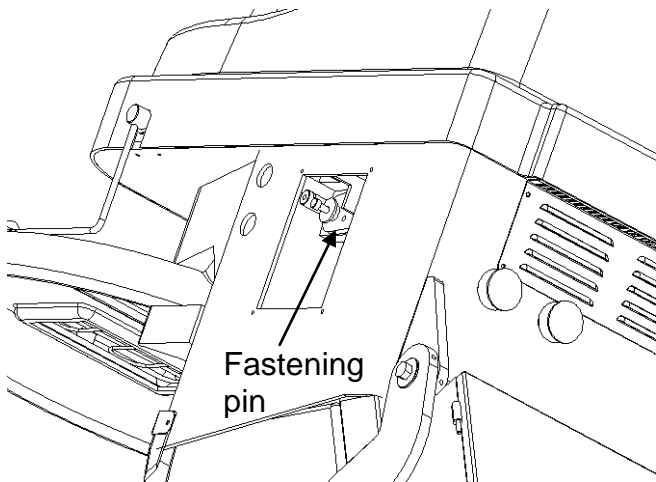

Diagram C

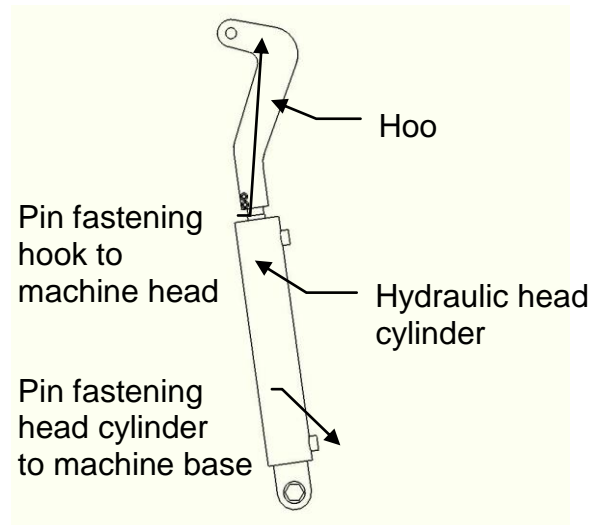

Diagram D

- Manually extend the special tie rod so as to open the machine head a little beyond its normal stroke, approximately a few centimetres above the plastic protective cover (Diagram B).

ATTENTION ! Do not excessively open the machine head as this could cause the machine to fall backwards if it has not been securely fastened to the floor !

- Remove the plastic protective cover (Diagram B).

- Remove the cover of the electrical panel at the back of the machine.

- Loosen and remove the central upper screw which fastens the electrical unit to the back of the machine and carefully tilt the electrical unit backwards, resting it on the floor.

- It is now possible to remove the hydraulic unit and hence gain access to the hydraulic cylinder head and hook.

- To remove the hydraulic cylinder head with hook, remove the pin at the base of the head cylinder which fastens it to the base of the machine.

19.5 Adjusting the pressure switches of the hydraulic unit

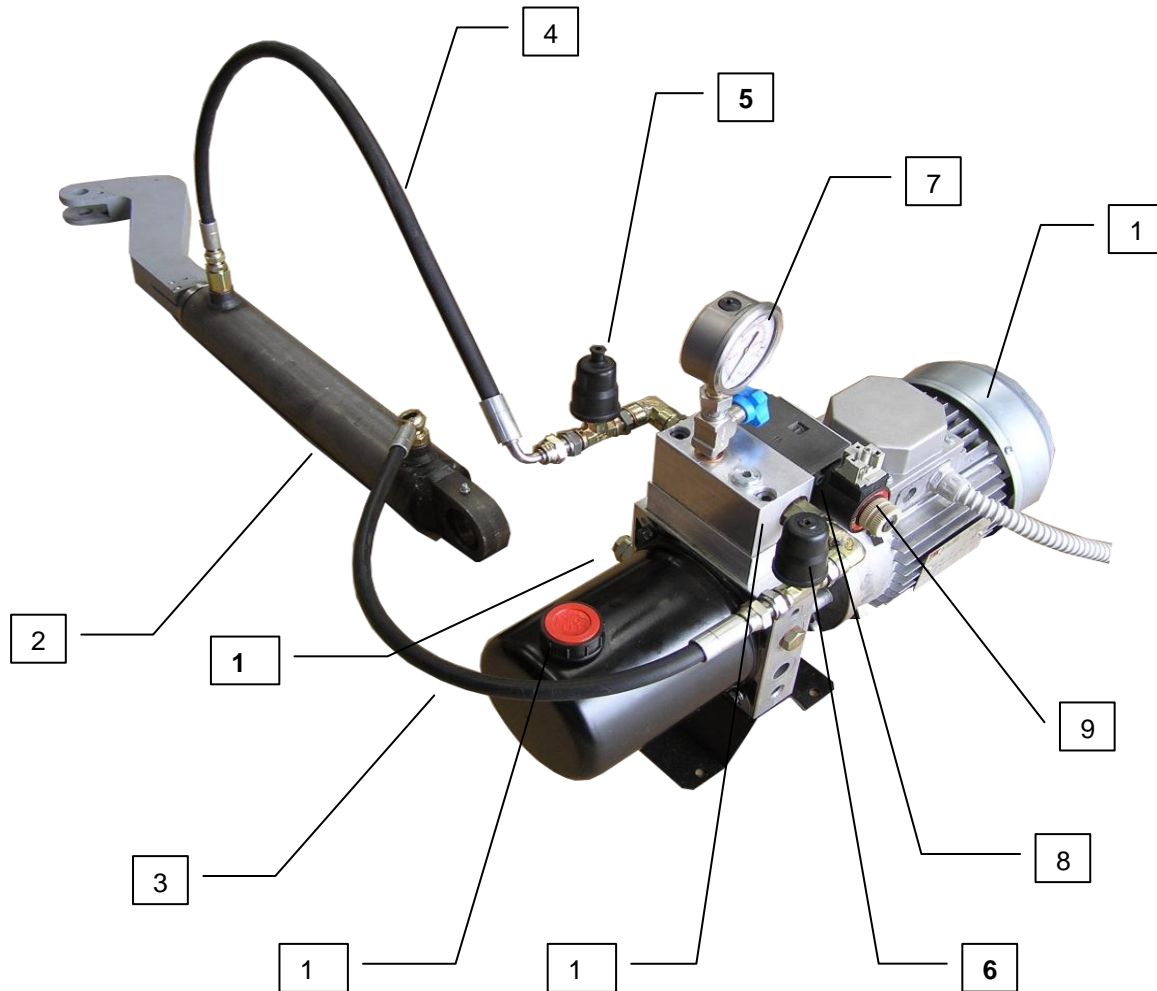

Figure 1

Pos.	Qty	Code	Description
1	1		Motor ST 80 0.75 kW
2	1	C01346	Head cylinder
3	1	C01348	Pipe for ascent l 550 mm
4	1	C01344	Pipe for descent l 600 mm
5	1	E00919	Oil pressure switch
6	1	E00919	Oil pressure switch
7	1	C00458	Pressure gauge mg 63 0-160
8	1		Valve ATOS DHI-0631/2
9	1		Solenoid ATOS SP-COU 24 V DC
10	1		Cap for adding oil OMT
11	1		Non return double valve
12	1		Hydraulic control valve
INT	1		Filter
INT	1		Hydraulic pump
INT	1		Joint ring (motor pump)

INT: internal components (not visible)

SPIRAL MIXER MAG-R 80

Date création : 12-09-2012

Date révision :

Code : B60006AV-0002

400V - 50HZ - Tri

Version :

Both oil pressure switches (pos. 5 and pos. 6 in Figure 1) are set at 90 bar (P1 – machine work pressure) during the manufacturer's machine testing phase. Their function is to stop the up- or down-stroke of the hydraulic piston when the machine head is completely open or completely closed.

A hydraulic control valve (pos. 12 in Figure 1) is incorporated into the hydraulic unit. Its function is to protect the hydraulic unit against excessive pressure. This valve is set at 110 bar (P2) during the manufacturer's machine testing phase; 20 bar more than the set machine work pressure P1

If for some reason, these pressure settings have changed, then it is necessary to reset both the values P1 and P2. This can be done following the procedure described hereafter.

Setting the pressure of the head down-stroke pressure switch (pos. 5) at 90 bar

1. Unscrew the blue valve on the pressure gauge (pos. 7) to allow the gauge to read the pressure.
2. With the head completely open, remove the two electrical wires that connect the pressure switch (pos. 5) to the electrical panel.
3. Using a small piece of electrical wire make a bridge across the two electrical wires which have been disconnected (point. no. 1). Tighten the red screw located on top of the pressure switch (pos. 5).
4. Press the Head Down button on the control panel. Once the machine head is completely closed, the hydraulic motor does not stop but carries on running, because of the bridge created in point no. 2. At this point, using the appropriate tools, it is necessary to loosen the hydraulic control valve until the pressure indicated on the pressure gauge (pos. 7 in Figure 1) reaches 90 bar.
5. Remove the electrical bridge and reconnect the two electrical wires from the pressure switch (pos. 5) to the electrical panel. **Slowly** loosen the red screw of oil pressure switch (pos. 5) until the hydraulic motor stops. At this point, the pressure switch (pos. 5) has been correctly set at 90 bar (P1).

Setting the pressure of the head up-stroke pressure switch (pos. 6) at 90 bar

6. Tighten the red screw located on top of the pressure switch (pos. 6).
7. Press the Head Up button on the control panel. Once the machine head is completely open, the hydraulic motor does not stop but carries on running.
8. **Slowly** loosen the red screw of oil pressure switch (pos. 6) until the hydraulic motor stops. At this point, the pressure switch (pos. 6) has been correctly set at 90 bar (P1).

Setting the pressure of the hydraulic control valve (pos. 12) at 110 bar

9. Once again, remove the two electrical wires that connect the pressure switch (pos. 5) to the electrical panel and make a bridge across the two electrical wires which have been disconnected.
10. Press the Head Down button on the control panel. Once the machine head is completely closed, the hydraulic motor does not stop but carries on running.
11. At this point, using the appropriate tools, it is necessary to tighten the hydraulic control valve until the pressure indicated on the pressure gauge (pos. 7 in Figure 1) reaches 110 bar (P2).
12. Fasten the lock nut on the hydraulic control valve to maintain the set pressure value.
13. Remove the electrical bridge and reconnect the two electrical wires from the pressure switch (pos. 5) to the electrical panel.
14. Screw the blue valve closed on the pressure gauge (pos. 7).

N.B.

(i) Technical data is not binding. The data can be changed in order to improve the product.

(ii) Drawings and illustrations are only indicative.

19.6 Hydraulic Diagram

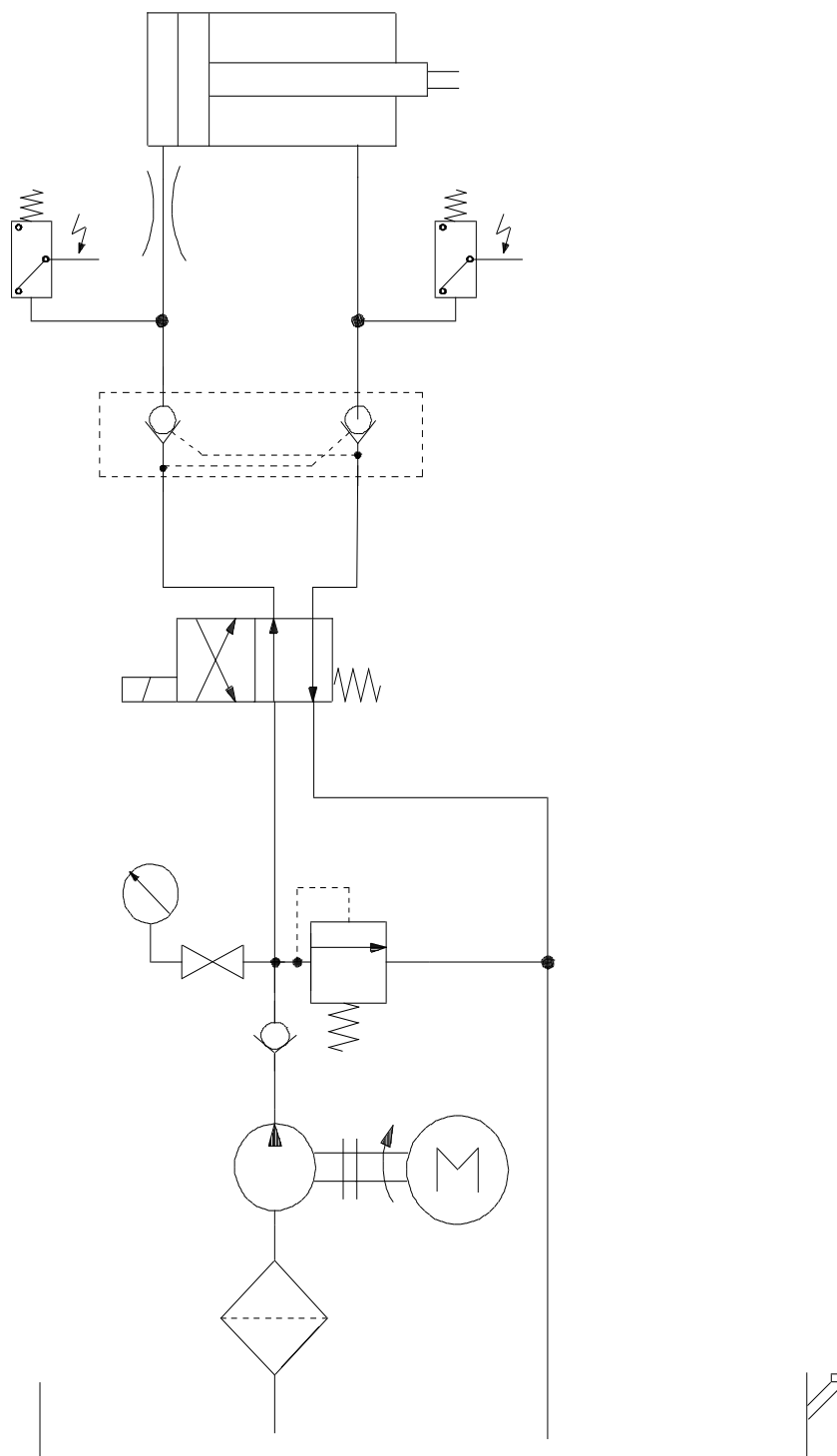

PRESSIONE DI ESERCIZIO 90 bar

SPIRAL MIXER MAG-R 80

Date création : 12-09-2012

Date révision :

Code : B600006AV-0002

400V - 50HZ - Tri

Version :

20 EXPLODED VIEWS OF MAG-R 80

20.1 General drawing

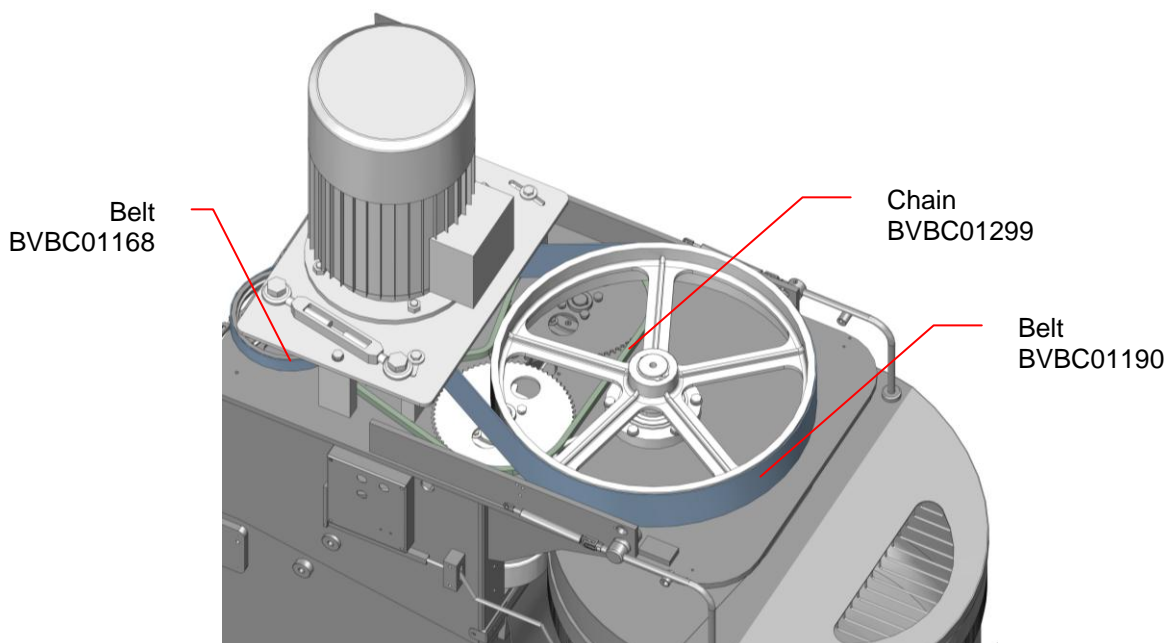
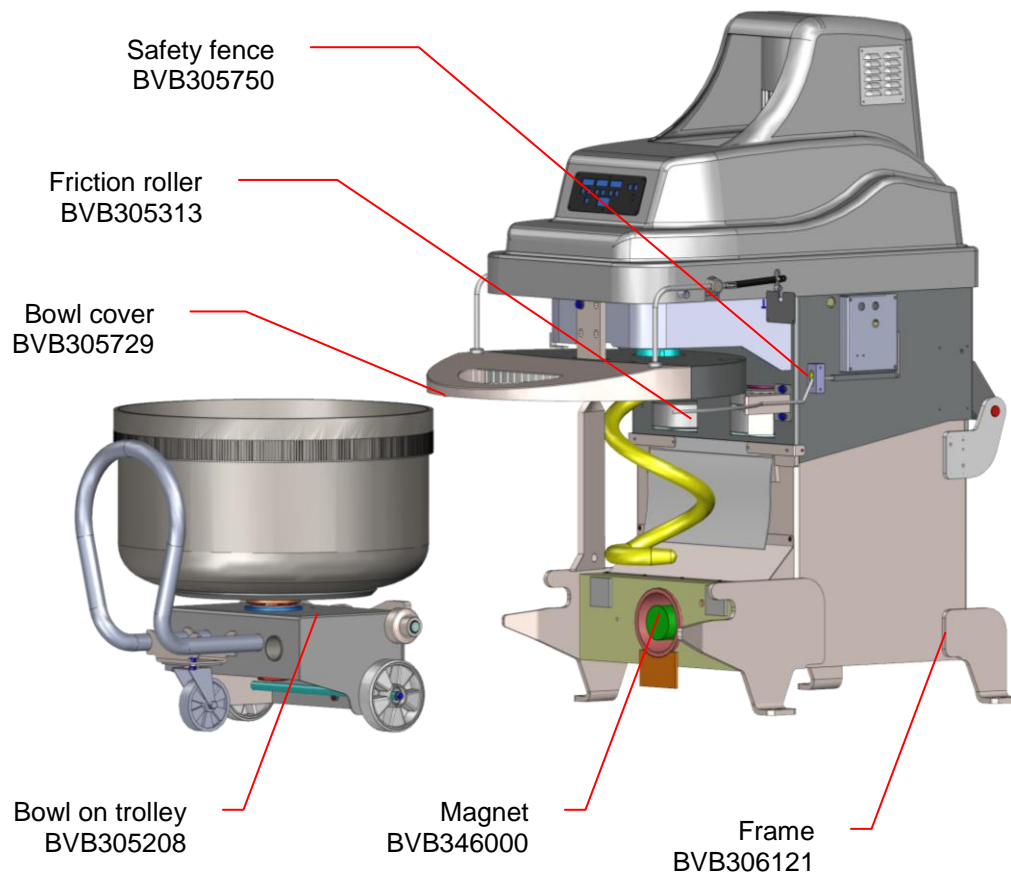

SPIRAL MIXER MAG-R 80

Date création : 12-09-2012

Date révision :

Code : B600006AV-0002

400V - 50HZ - Tri

Version :

20.2 Spiral - BVB305023

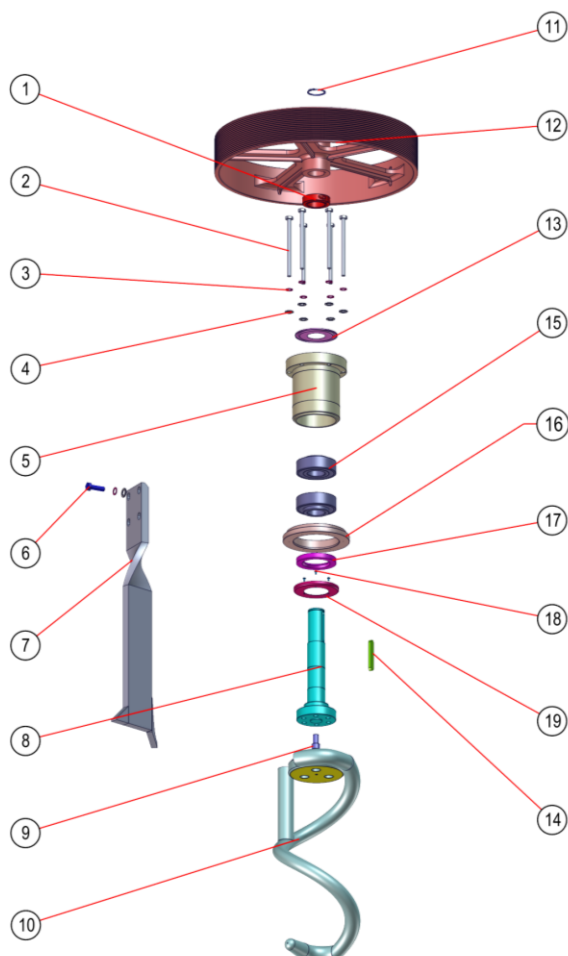

Pos	Désignation	Nbr	Code
1	Brake nut	1	BVB107003
2	Shaft bearing	1	BVB163028
2	Screw	6	BVBC01182
3	Washer	6	BVBC00085
4	Washer	6	BVBC00074
6	Screw	4	BVBC00173
7	Center post	1	BVB177030
8	Shaft	1	BVB100069
9	Screw	3	BVBC00028
10	Spiral	1	BVB220025
11	Circlips ce 42	1	BVBC01185
12	Pulley	1	BVB180049
13	Sealing collar	1	BVBC01181
14	Key shaft	1	BVBC01184
15	Bearing	2	BVBC01176
16	Locking collar	1	BVB104017
17	Lip seal	1	BVBC01177
18	Screw	3	BVBC01130
19	Shaft cover	1	BVB108007
	Grease	0,008	BVBC00353
	Pneumatic connexion	2	BVBC01379
	In let	1	BVBC01135
	Tube	1	BVBC01136
	Washer	4	BVBC00075
	Washer	4	BVBC00086
	Pneumatic connexion	1	BVBC01137

SPIRAL MIXER MAG-R 80

Date création : 12-09-2012

Date révision :

Code : B600006AV-0002

400V - 50HZ - Tri

Version :

20.3 Spiral motor - BVB305117

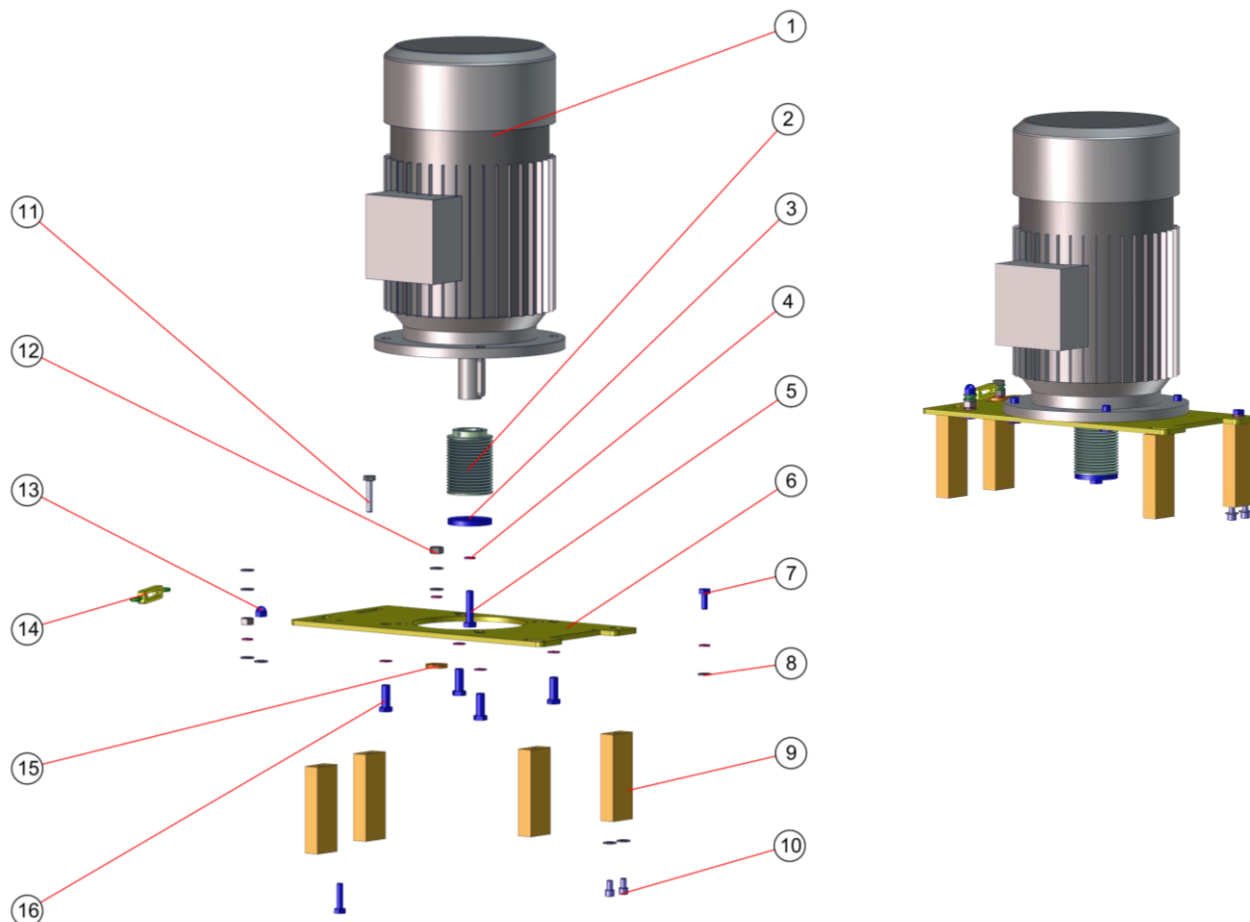

Pos	Désignation	Nbr	Code
	Washer	5	BVBC00086
	Washer	4	BVBC00075
	Screw	1	BVBC00578
	Cable	1	BVBE01181
	Screw	2	BVBC01250
	Pin for brace	2	BVB186096
1	Motor	1	BVBE00635
2	Pulley	1	BVB183073
3	Washer	1	BVB211023
4	Washer	5	BVBC00085
5	Screw	1	BVBC00174
6	Motor support	1	BVB231016
7	Screw	3	BVBC00000
8	Washer	15	BVBC00074
9	Bloc	4	BVB113030
10	Screw	8	BVBC00551
11	Screw	1	BVBC00008
12	Nut	2	BVBC00247
13	Nut	1	BVBC00053
14	Tension device	1	BVBC01180
16	Washer	3	BVB211011
17	Screw	4	BVBC00015

SPIRAL MIXER MAG-R 80

Date création : 12-09-2012

Date révision :

Code : B600006AV-0002

400V - 50HZ - Tri

Version :

20.4 Galet de friction - BVB305313

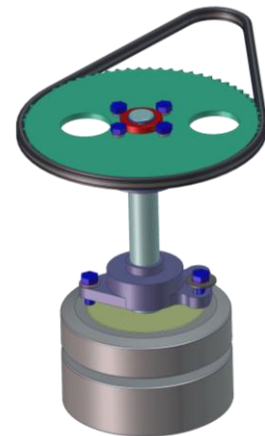
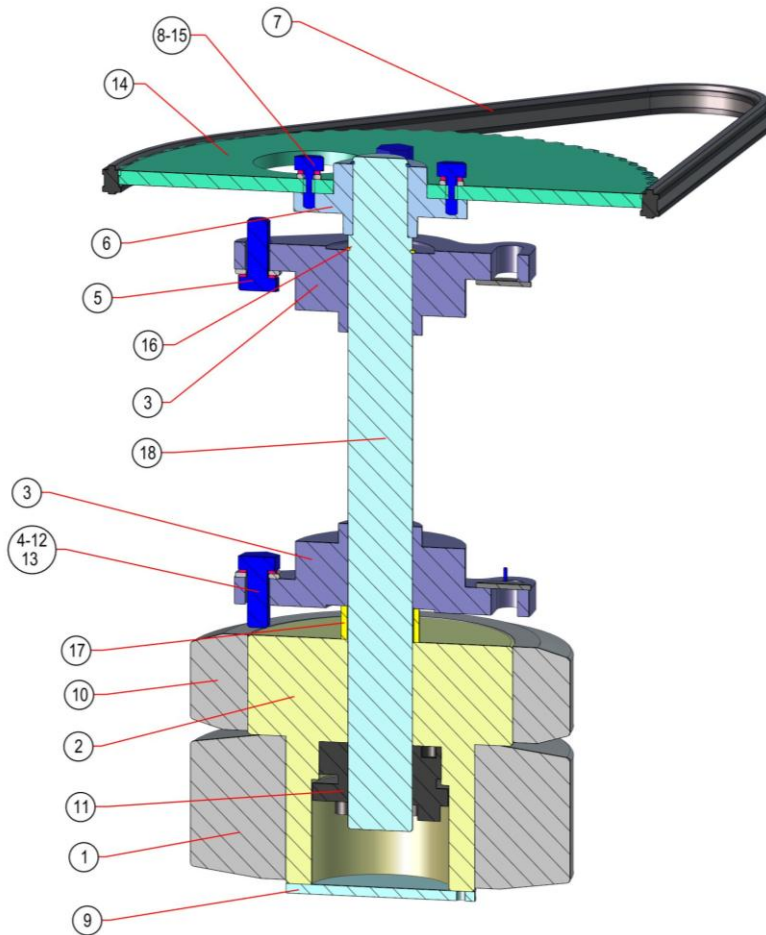

Pos	Désignation	Nbr	Code
	Washer	4	BVBC00073
	Washer	4	BVBC00521
	Key shaft	1	BCL080730
1	Rubber ring	1	BVBC01154
2	Bearing for rubber ring	1	BVB163029
3	Bearing	2	BVBC00250
4	Washer	4	BVBC00086
5	Washer	2	BVBC00075
6	Support	1	BVB163024
7	Simple chain	1	BVBC01299
8	Circlips	1	BVBC00057
9	Protection disc	1	BVB142021
10	Rubber ring	1	BVBC01153
11	Binder	1	BVBC01212
12	Washer	2	BVBC00205
13	Screw	4	BVBC00009
14	Crown	1	BVB157013
15	Screw	4	BVBC00576
16	Circlips	1	BVBC00246
17	Brace	1	BVB143042
18	Shaft	1	BVB100070

20.5 Return pulley - BVB305312

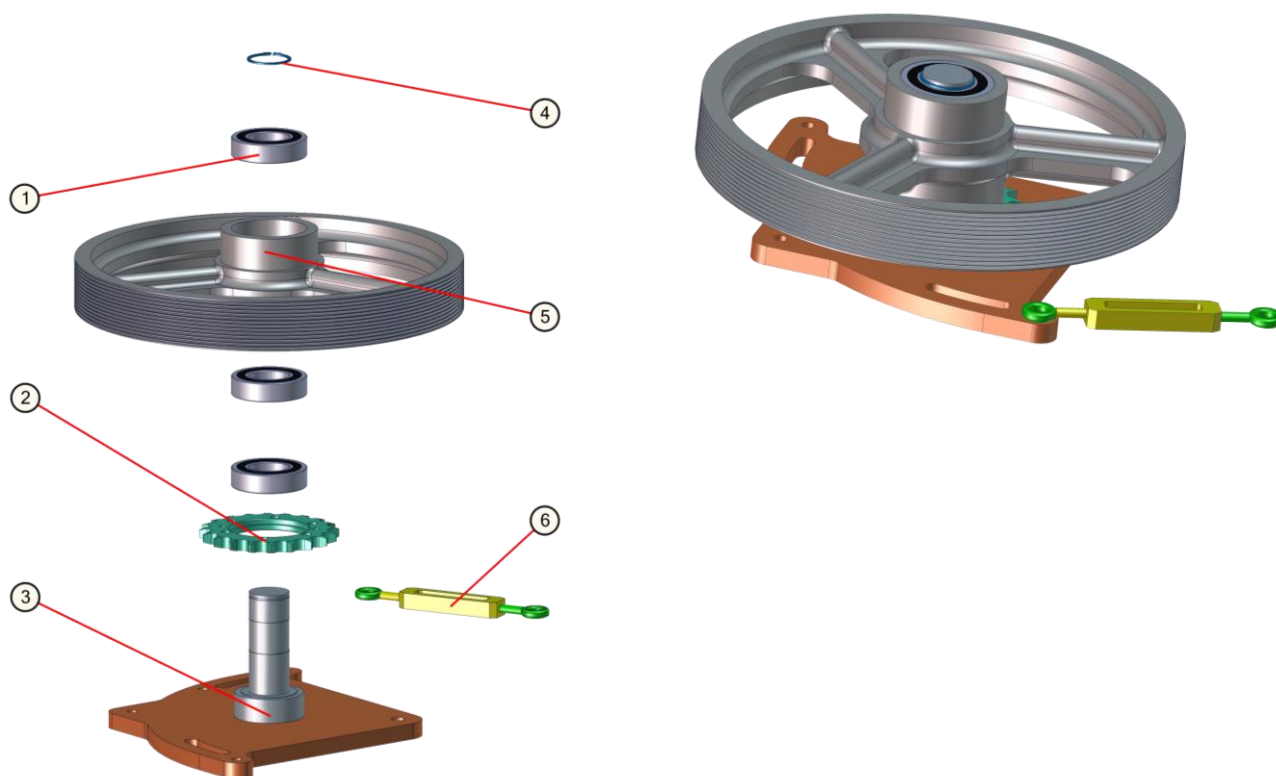

Pos	Désignation	Nbr	Code
	Screw	6	BVBC00390
	Washer	6	BVBC00073
	Washer	4	BVBC00521
	Screw	3	BVBC00487
	Washer	2	BVBC00376
	Nut	2	BVBC00048
	Screw	1	BVBC01148
	Screw	1	BVBC01159
1	Bearing	3	BVBC01274
2	Crown	1	BVB157011
3	Support	1	BVB216093
4	Circlips	1	BVBC00530
5	Pulley	1	BVB180048
6	Tension device	1	BVBC01158

SPIRAL MIXER MAG-R 80

Date création : 12-09-2012

Date révision :

Code : B600006AV-0002

400V - 50HZ - Tri

Version :

20.6 Bowl motor - BVB305405

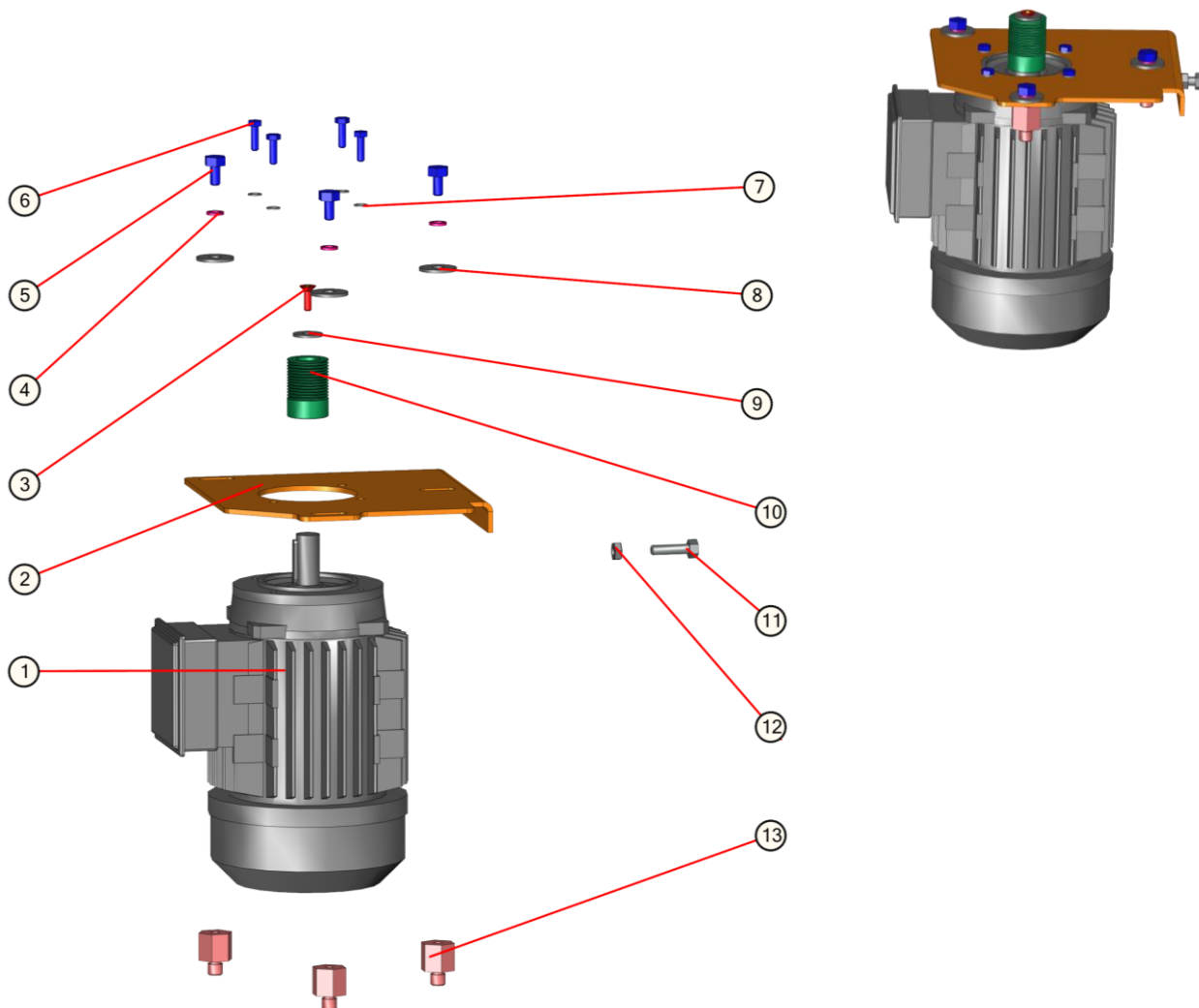

Pos	Désignation	Nbr	Code
	Cable	1	BVBE00627
	Tube	1	BVBE01283
1	Motor	1	BVBE00822
2	Motor plate	1	BVB191089
3	Screw	1	BVBC00032
4	Washer	3	BVBC00521
5	Screw	3	BVBC00005
6	Screw	4	BVBC00352
7	Washer	4	BVBC00072
8	Washer	1	BVBC00486
9	Washer	3	BVBC00376
10	Pulley	1	BVB183070
11	Screw	1	BVBC00006
12	Nut	1	BVBC00048
13	Pin	3	BVB186099

20.7 Stop - BVB305607

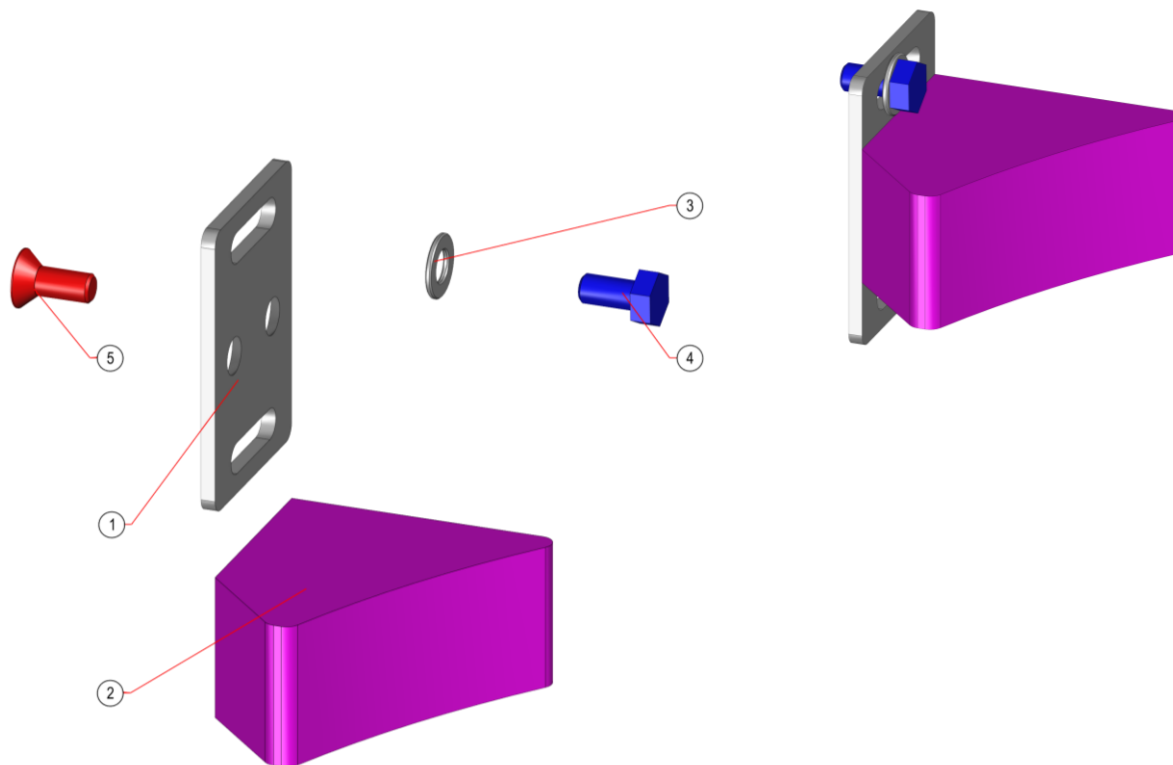

Pos	Désignation	Nbr	Code
1	Plate	2	BVB191090
2	Bowl booster	2	BVB113034
5	Screw	4	BVBC00030
3	Washer	4	BVBC00074
4	Screw	4	BVBC00576

20.8 Safety fence - BVB305750

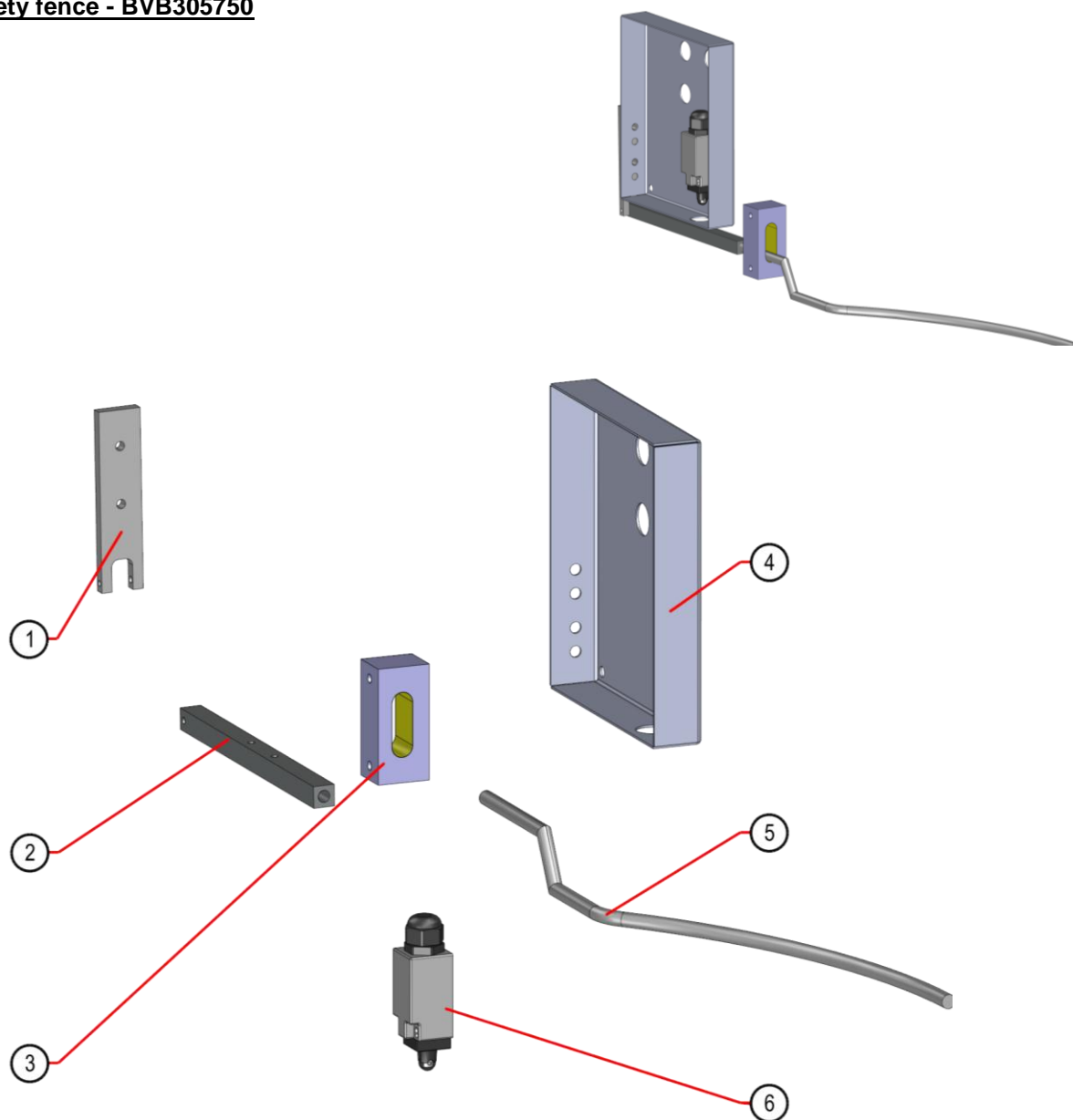

Pos	Désignation	Nbr	Code
4	carter	1	BVB208142-9007
2	Lever	1	BVB161005
3	Bloc	1	BVB113037
1	Plate	1	BVB188166
5	Lever	1	BVB161008
6	Micro interruptor	1	BVBE00028

20.9 Bowl trolley - BVB305208

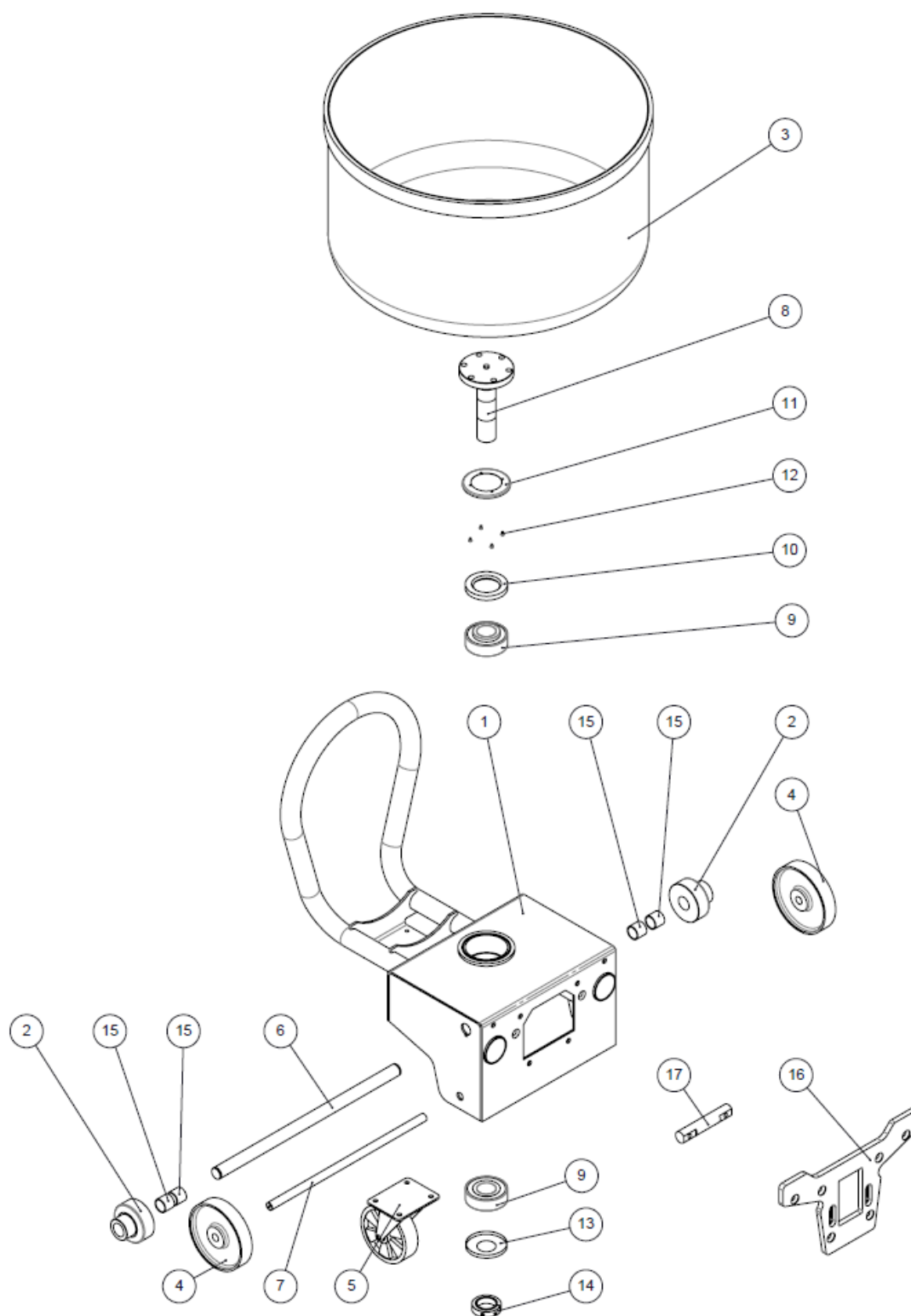

SPIRAL MIXER MAG-R 80

Date création : 12-09-2012

Date révision :

Code : B600006AV-0002

400V - 50HZ - Tri

Version :

Pos	Désignation	Nbr	Code
1	Carriage base – 80 model	1	BVB140013
2	Carriage centring wheel	2	BVB200014
3	Bowl – 80 model	1	BVB261076
4	Bowl carriage wheels	2	BVBC01175
5	Revolving support with wheel	1	BVBC01142
6	Pin for centring wheels	1	BVB186103
7	Pin for bowl carriage wheels	1	BVB186102
8	Bowl shaft	1	BVB100068
9	Bearing 32309	2	BVBC01718
10	Sealing ring – type: MIM (60x100x12)	1	BVBC01177
11	Cover for bowl shaft	1	BVB108006
12	Screw M4x6	4	BVBC01130
13	Sealing ring NILOS 32309 type: AV	1	BVBC01178
14	Lock nut	1	BVB107003
15	Self-lubricating bush	4	BVBC01222
16	Plate for hook	1	BVB191179
17	Pin for hook	1	BVB186155

SPIRAL MIXER MAG-R 80

Date création : 12-09-2012

Date révision :

Code : B600006AV-0002

400V - 50HZ - Tri

Version :

20.10 Bowl cover - BVB305729

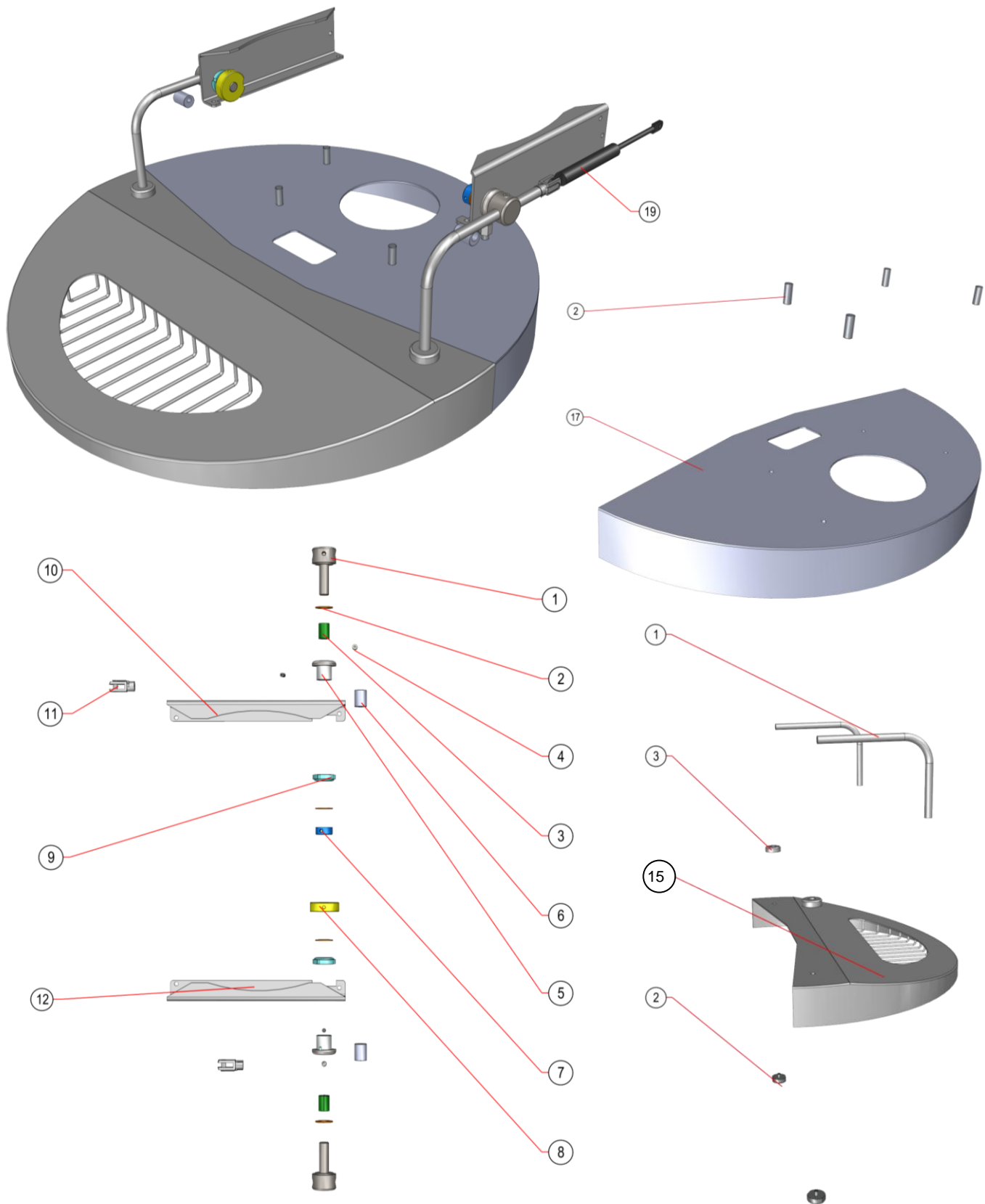

SPIRAL MIXER MAG-R 80

Date création : 12-09-2012

Date révision :

Code : B600006AV-0002

400V - 50HZ - Tri

Version :

Pos	Désignation	Nbr	Code
	Closing plate	2	BVB159262
	Screw	6	BVBC00003
	Washer	6	BVBC00072
	Support	2	BVB234031
	Collar	4	BVB116055
	Screw	4	BVBC00352
	Washer	4	BVBC00373
	Screw	2	BVBC00594
	Nut	2	BVBC00242
	Back collar	2	BVB116061
	Pin	2	BVBC00889
	Screw	3	BVBC00042
	Collar	2	BVB116032
1	Mobil cover pin	2	BVB186088
2	Washer	4	BVBC00240
3	Collar	2	BVBC00864
4	Screw	2	BVBC01072
5	Collar	2	BVB116040
6	Excentric stop	2	BVB116001
7	Locking collar	1	BVBC00960
8	Cam	1	BVB131001
9	Nut	2	BVBC00839
10	Pin support	1	BVB234033-9007
11	Fork	2	BVBC01108
12	Pin support	1	BVB234034
13	Arm	2	BVB118078
14	Washer	2	BVB211001
15	Mobil cover	1	BVB202052
16	Pin	2	BVB186004
17	Fixed cover	1	BVB205039
18	Pin	4	BVB186115
19	Cylinder	2	BVBC01209

SPIRAL MIXER MAG-R 80

Date création : 12-09-2012

Date révision :

Code : B600006AV-0002

400V - 50HZ - Tri

Version :

20.11 Frame - BVB306121

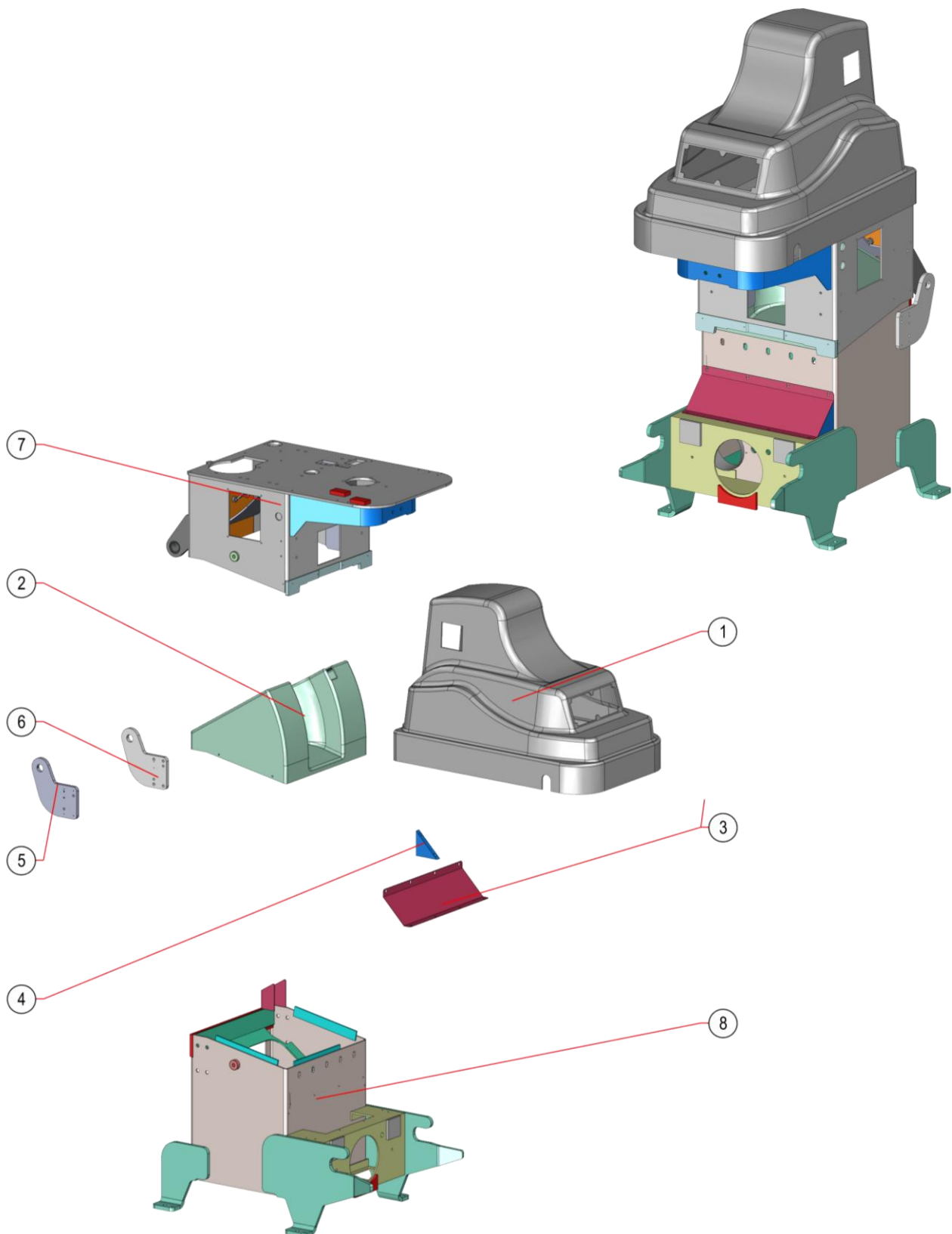

SPIRAL MIXER MAG-R 80

Date création : 12-09-2012

Date révision :

Code : B600006AV-0002

400V - 50HZ - Tri

Version :

Pos	Désignation	Nbr	Code
1	Head cover	1	BVB125059
2	Carter	1	BVB208111
3	Reinforcing plate	1	BVB159131
4	Reinforcing plate	2	BVB188131
5	Plate	1	BVB191094-9007
6	Plate	1	BVB191093-9007
7	Head	1	BVB247047-9007
8	Frame	1	BVB285076-9007
	Back carter	1	BVB208112-9007
	Fixing plate	2	BVB159132
	Threated rod	1	BVBC01172
	Nut	2	BVBC01189
	Nut	2	BVBC01171
	Pin	1	BVB100071
	Screw	4	BVBC01078
	Washer	16	BVBC00075
	Screw	8	BVBC00794
	Screw	5	BVBC01192
	Plate	1	BVB188142-9007
	Collar	2	BVBC01193
	Screw	8	BVBC01245
	Screw	4	BVBC00504
	Screw	6	BVBC00807
	Caoutchouc plate	0,900	BVBC01240
	Washer	6	BVBC00071
	Screw	6	BVBC00002
	Washer	4	BVBC00373
	Washer	2	BVBC00511
	Screw	2	BVBC00440
	Support	1	BVB234038
	Ventilator	1	BVBE00845
	Washer	8	BVB211027
	Washer	4	BVB211028
	Micro switch	1	BVBE00028
	Screw	2	BVBC00022
	Washer	2	BVBC00071
	Washer	2	BVBC00084
	Cartzer	1	BVB208170-9007
	Screw	4	BVBC00236
	Came	1	BVB131007
	Shim	1	BVB188177
	Screw	2	BVBC00003

20.12 hydraulic station

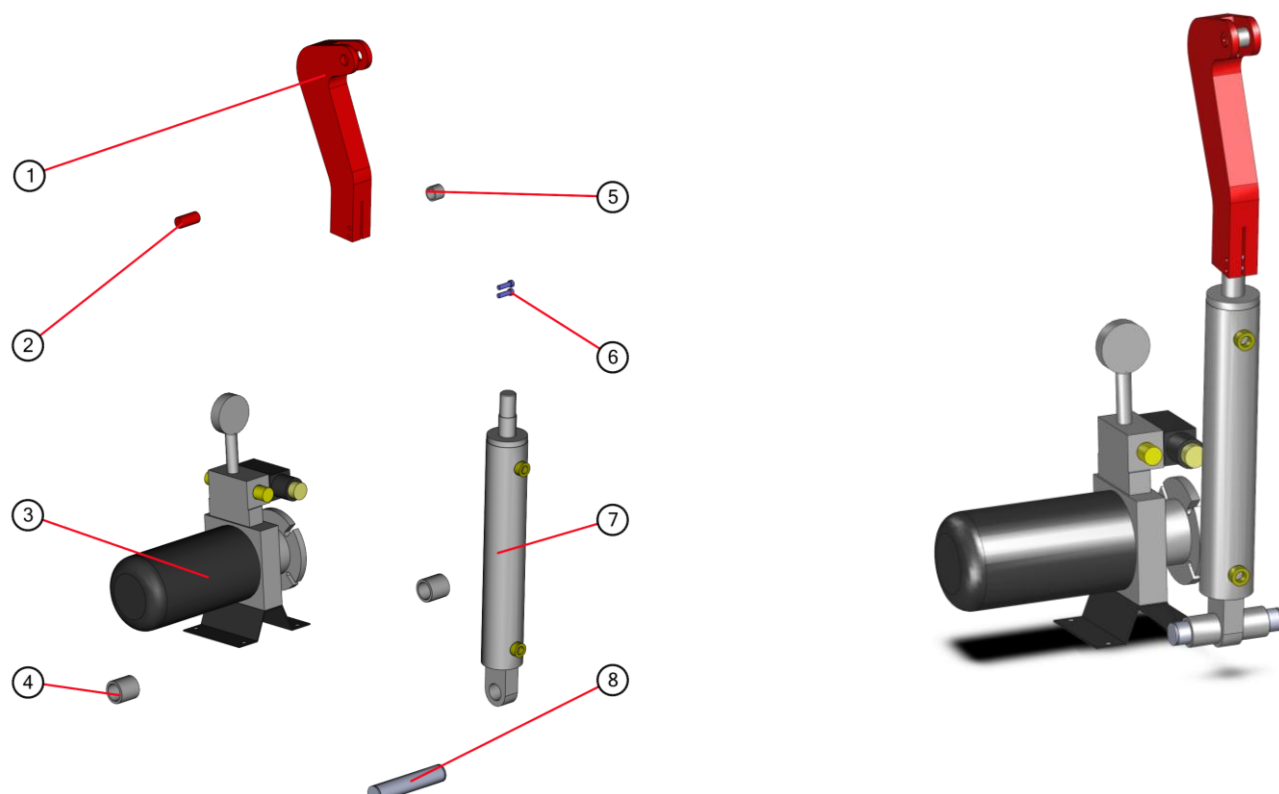

Pos	Désignation	Nbr	Code
4	Bloc	1	BVBC01341
7	Hydraulic cylinder	1	BVBC01346
	Kit	1	BVBC01349
	Hydraulic flexible	1	BVBC01348
	Hydraulic flexible	1	BVBC01344
1	Hook	1	BVB154006
2	Pin	1	BVB186100
	Washer	2	BVBC00376
	screw	2	BVBC00005
6	Screw	2	BVBC01167
8	Pin	1	BVB186151
4	Brace	2	BVB143044
	Pressostat	2	BVBE00919
5	Collar	1	BVBC01191
	Cablr	1	BVBE00977
	Tube	1	BVBE01283
	Hydraulic connexion	2	BVBC00869

SPIRAL MIXER MAG-R 80

Date création : 12-09-2012

Date révision :

Code : B600006AV-0002

400V - 50HZ - Tri



Version :

21 WIRING DIAGRAMS: BVBE01056

FOLIO	SOMMAIRE	
02	FOLIO PUISSANCE	POWER SHEET
03	FOLIO COMMANDE	PWER SHEET
04	FOLIO COMMANDE	POWER SHEET
05	FOLIO COMMANDE	POWER SHEET
06	FOLIO DESIGNATION	DESIGNATION SHEET
07	BORNIER : X1	CONNECTORS : X1
08	CONNECTEUR: JF PUPITRE D	CONNECTORS : JF PUPITRE D
10	CONNECTEUR: JF PUPITRE G	CONNECTORS : JF PUPITRE G
11	CONNECTEUR: JF ELECTROVANNES	CONNECTORS : JF ELECTROVANNES
12	CONNECTEUR: JF MINUTERIE	CONNECTORS : JF MINUTERIE
13	TABLEAU DES FILS	WIRE TABLE
14	IMPLANTATION ARMOIRE	LAY OUT OF CABINET
15	PORTE ARMOIRE	DOOR OF CABINET
16	COTE ET DERRIERE ARMOIRE	SIDE AND BEHIND OF CABINET
17	PUPITRE	SWITCHES

FOLIO	SOMMAIRE	
18	COTÉ DROIT PETRIN	RIGHT SIDE OF MIXER
19	COTÉ GAUCHE PETRIN	LEFT SIDE OF MIXER
20	SYNOPTIQUE	SYNOPTIC
21	NOMENCLATURE DÉTAILLÉE	NOMENCLATURE SHEET
22	NOMENCLATURE DÉTAILLÉE	NOMENCLATURE SHEET
23	NOMENCLATURE DÉTAILLÉE	NOMENCLATURE SHEET
24	NOMENCLATURE DÉTAILLÉE	NOMENCLATURE SHEET

A	CREATION DU DOSSIER	16/01/2013	Olivier FONTENEAU
INDICE	INTITULE DE L'INDICE	DATE	DESSINATEUR

TENSION PUISSANCE : 400 V TENSION COMMANDE : 24VAC / 24-48VDC FREQUENCE : 50 Hz PUISSANCE TOTALE : 9.3 KW INTENSITE TOTALE : 20 A	DATE : 15/09/2014
	GROUPE : AG NB DE FOLIO : 23
MAG R 80 / 120	SCHEMA : E01056
	Groupe VMI : Z.I. Nord 85607 Montaigu Cedex - France Tél. 33 (0)2 51 45 35 35 Fax 33 (0)2 51 06 40 84 email be-elec@vmi.fr
 THE MIXING COMPANY	

A
B
C
D
E
F
G
H
I
J
K
L
M
N

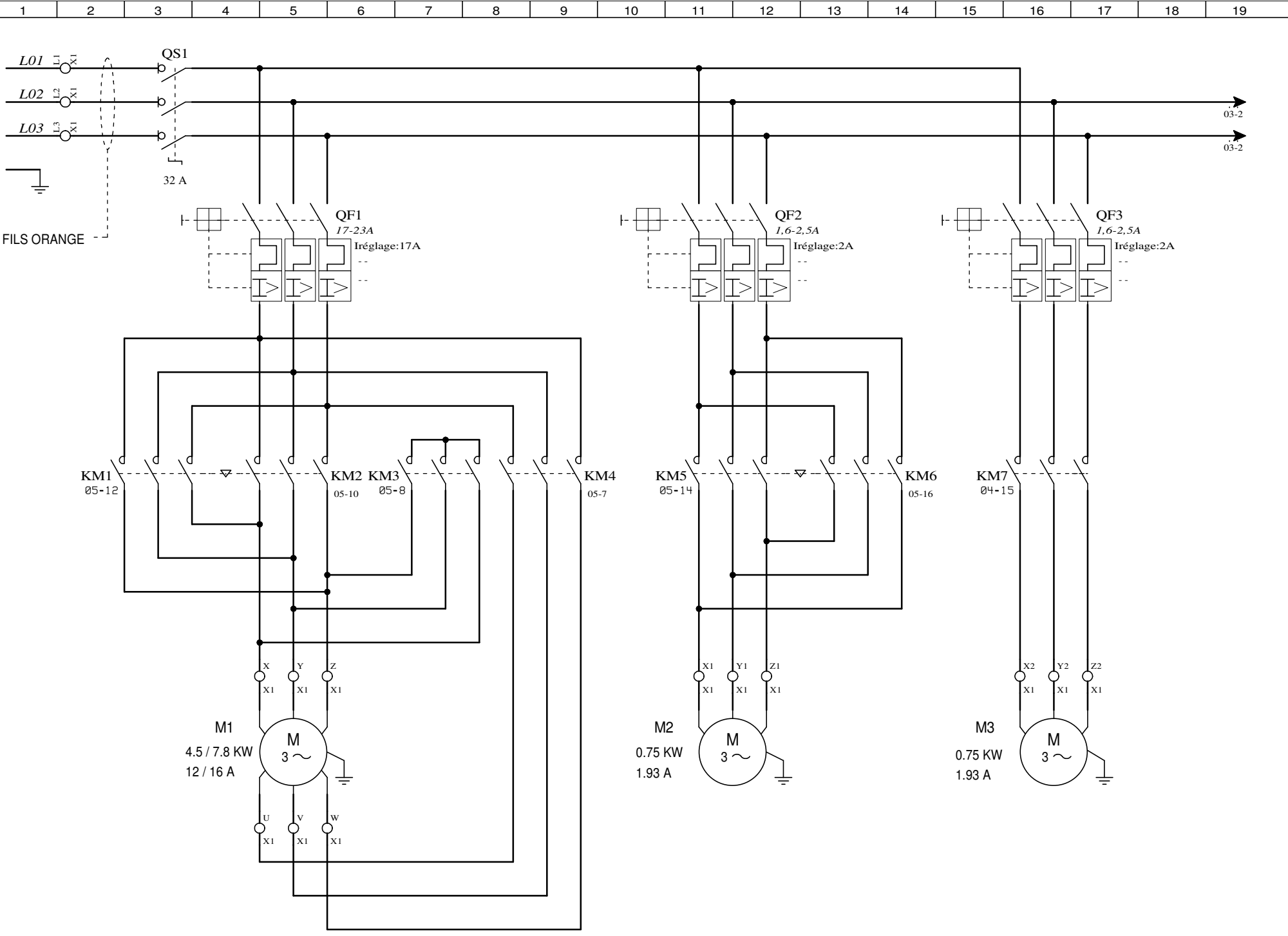

MOTEUR OUTIL
TOOL MOTOR

MOTEUR CUVE
BOWL MOTOR

CENTRALE HYDRAULIQUE
HYDRAULIC UNIT



Z.I. Nord 85607 Montaignu Cedex - France

Tel. 33 (0)2 51 45 35 35 - email be-elec@vmi.fr

AG

DOSSIER : MAG R 80 / 120

DESIGN : FOLIO PUISSANCE

02 / 23

SCHEMA N° : E01056

DES. PAR : OF

INDICE : A

LE : 16/01/2013

01

03

A
B
C
D
E
F
G
H
I
J
K
L
M
N

1 2 3 4 5 6 7 8 9 10 11 12 13 14 15 16 17 18 19

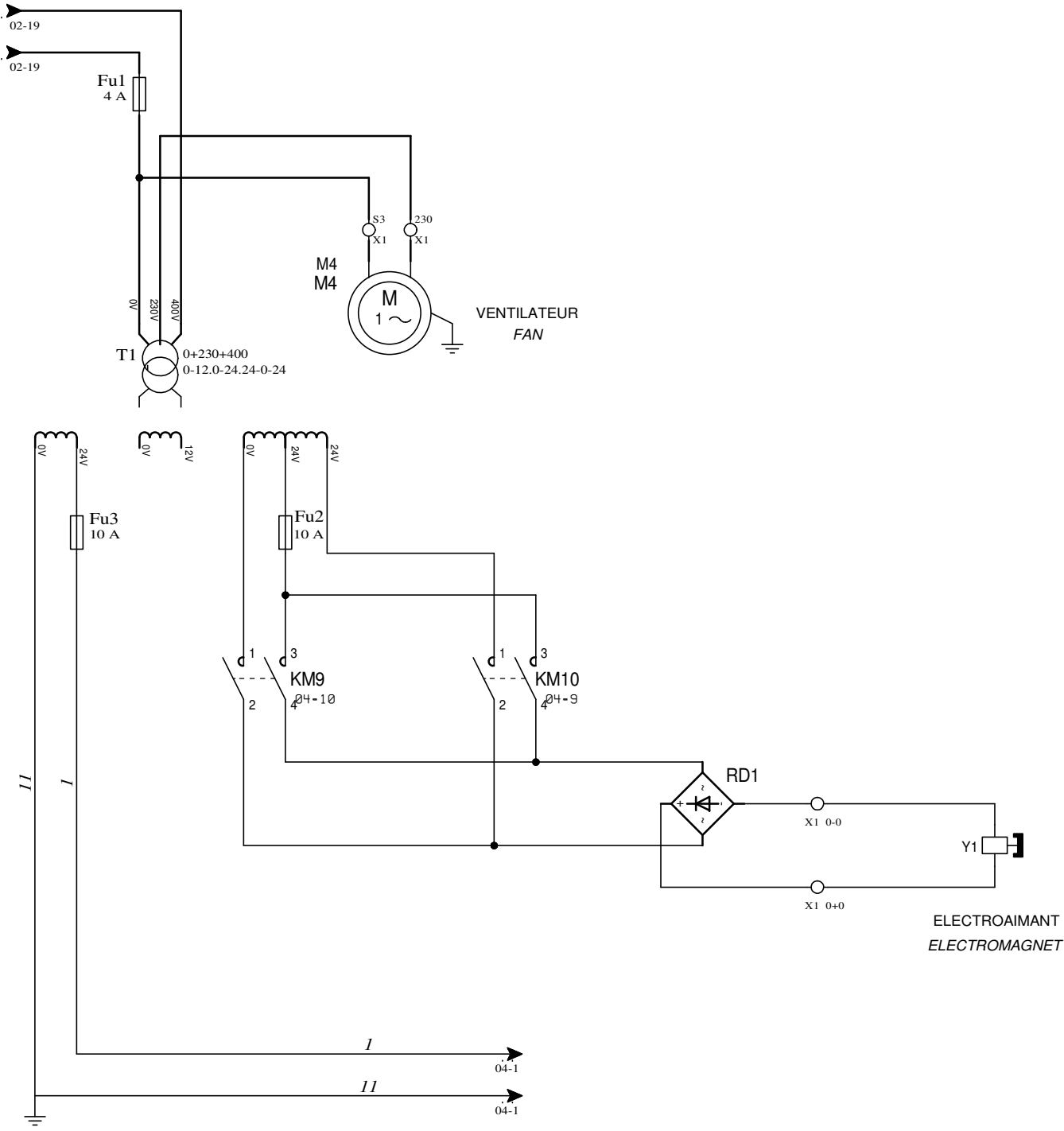

Z.I. Nord 85607 Montaignu Cedex - France

Tel. 33 (0)2 51 45 35 35 - email be-elec@vmi.fr

AG

DOSSIER : MAG R 80 / 120

DESIGN : FOLIO COMMANDE

03 / 23

SCHEMA N° : E01056

DES. PAR : OF

INDICE : A

LE : 16/01/2013

02 04

A
B
C
D
E
F
G
H
I
J
K
L
M
N

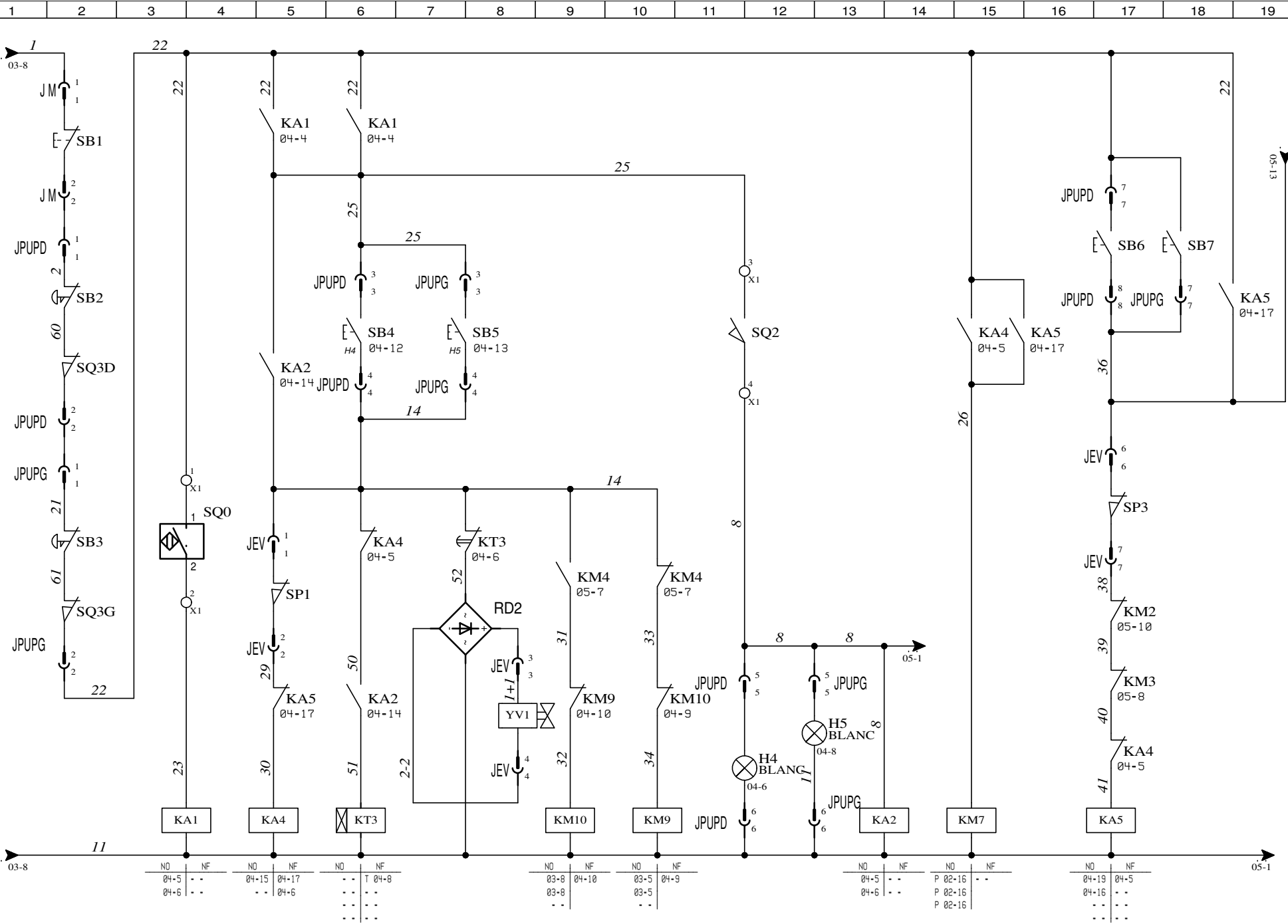

PRESENCE CUVE
BOWL PRESENCE

DESCENTE TETE
LOWERING HEAD

CENTRALE HYDRAULIQUE
HYDRAULIC UNIT

MONTEE TETE
LIFTING HEAD

NO	NF	NO	NF	NO	NF	NO	NF	NO	NF	NO	NF	NO	NF	NO	NF	NO	NF
04-5	..	04-15	04-17	..	T 04-8
04-6	04-6
..

Z.I. Nord 85607 Montaiigu Cedex - France
 Tël. 33 (0)2 51 45 35 35 - email be-elec@vmi.fr
 DOSSIER : MAG R 80 / 120
 DESIGN. : FOLIO COMMANDE
 DES. PAR : OF
 INDICE : A
 LE : 16/01/2013
 AG
 04 / 23
 SCHEMA N° : E01056
 03
 05

A
B
C
D
E
F
G
H
I
J
K
L
M
N

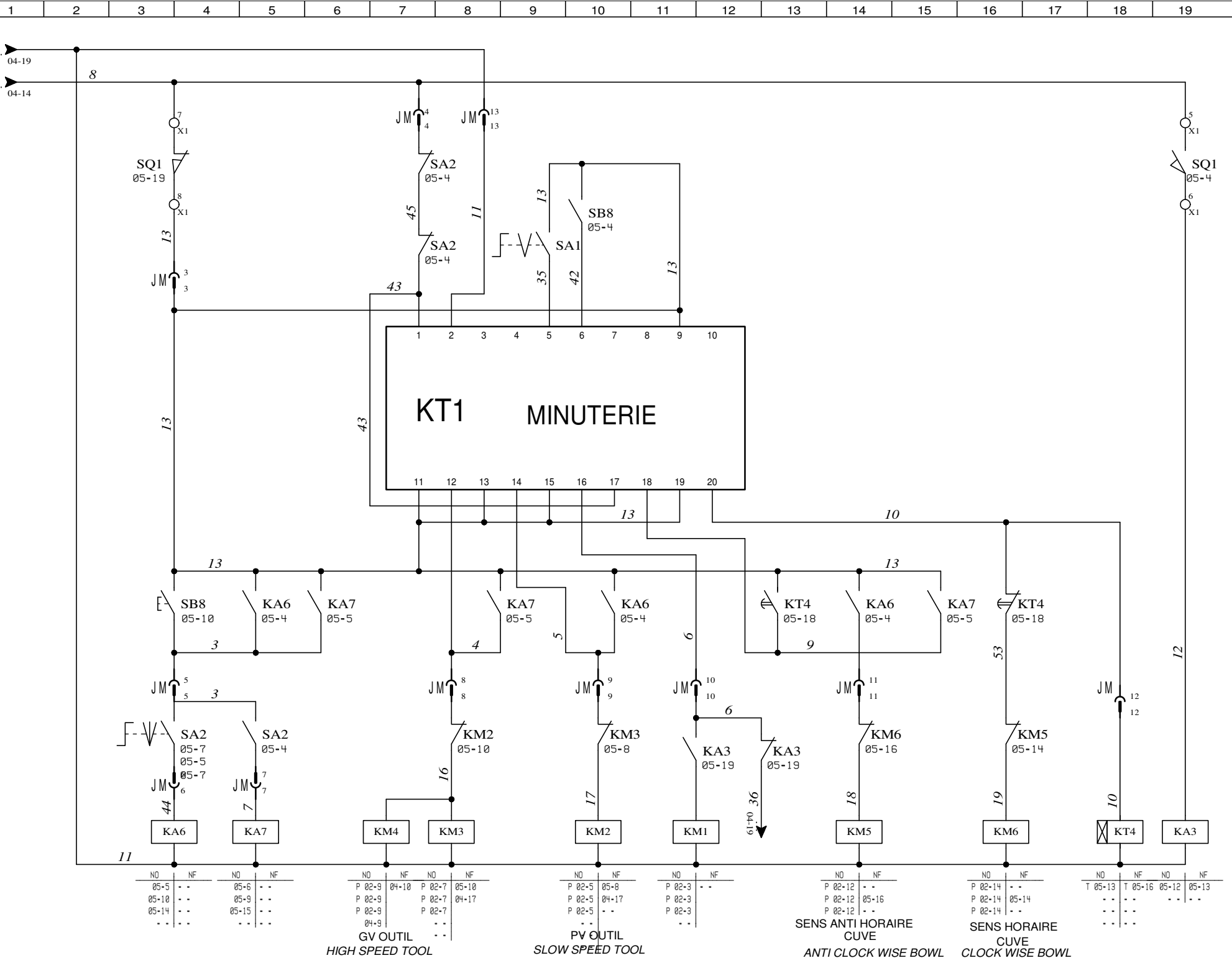

NO	NF	NO	NF	NO	NF	NO	NF	NO	NF	NO	NF	NO	NF	NO	NF	NO	NF	NO	NF	NO	NF	NO	NF	NO	NF	NO	NF	
05-5	..	05-6	..	P 02-9	04-10	P 02-7	05-10	P 02-5	05-8	P 02-3	..	P 02-12	..	P 02-14	..	T 05-13	T 05-16	05-12	05-13
05-10	..	05-9	..	P 02-9	..	P 02-7	04-17	P 02-5	04-17	P 02-3	..	P 02-12	05-16	P 02-14	05-14
05-14	..	05-15	..	P 02-9	..	P 02-7	..	P 02-5	..	P 02-3	..	P 02-12	..	P 02-14
..

GV OUTIL
HIGH SPEED TOOL

PV OUTIL
SLOW SPEED TOOL

SENS ANTI HORAIRE
CUVE
ANTI CLOCK WISE BOWL

SENS HORAIRE
CUVE
CLOCK WISE BOWL

THE MIXING COMPANY
 Z.I. Nord 85607 Montaiigu Cedex - France
 Tél. 33 (0)2 51 45 35 35 - email be-elec@vmi.fr

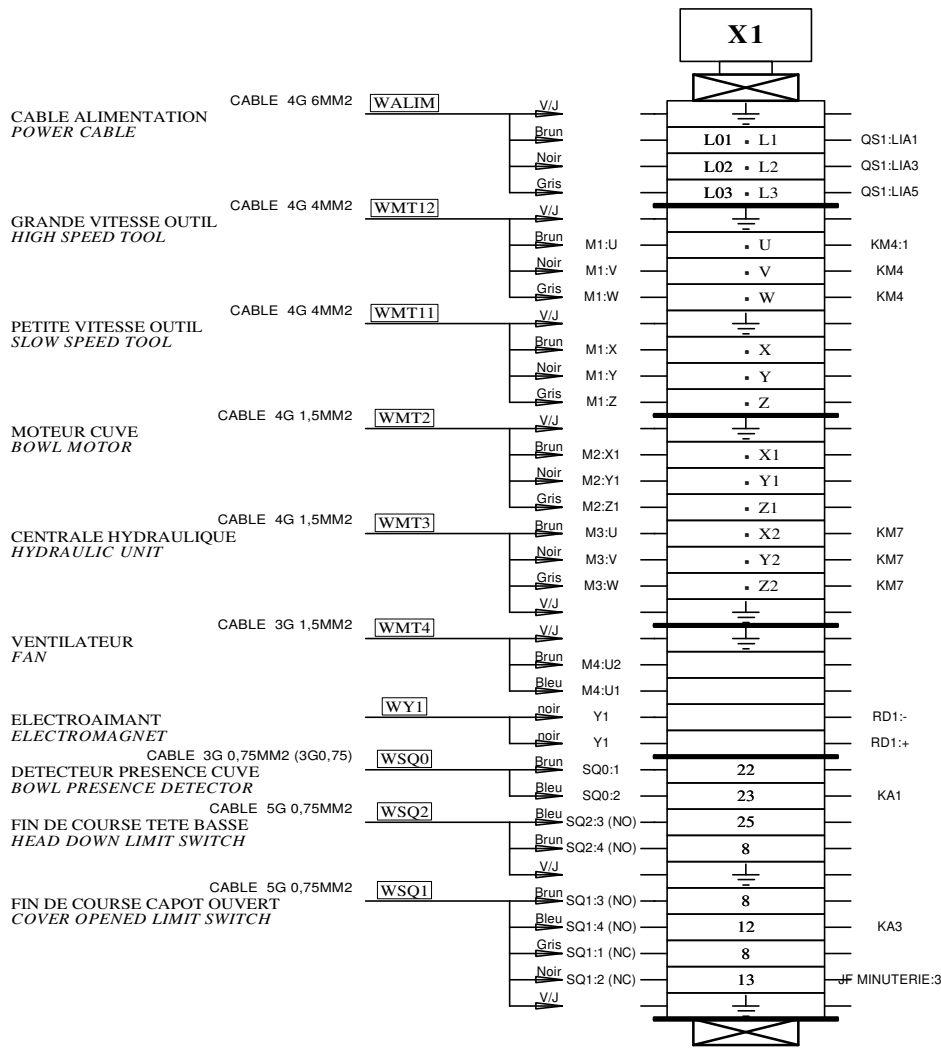

JF PUPITRE D
JF PUPITRE D

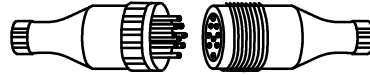

RESERVE		
RESERVE		
RESERVE		
RESERVE		
RESERVE		
2	1	JF MINUTERIE:2
21	2	JF PUPITRE G:1
25	3	
14	4	
8	5	
11	6	
22	7	
36	8	
RESERVE	9	
RESERVE	10	

JM PUPITRE D
JM PUPITRE D

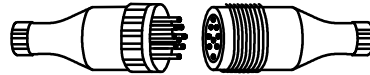

RESERVE		
RESERVE		
RESERVE		
RESERVE		
RESERVE		
2	1	SB2
21	2	SQ3D:2 (NC)
25	3	SB4:13
14	4	SB4:14
8	5	SB4:X1
11	6	SB4:X2
22	7	SB6
36	8	SB6
RESERVE	9	
RESERVE	10	

JF PUPITRE G
JF PUPITRE G

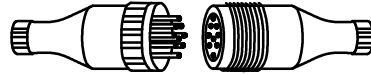

RESERVE		
RESERVE		
RESERVE		
RESERVE		
21	1	JF PUPITRE D:2
22	2	
25	3	
14	4	
8	5	
11	6	
36	7	
RESERVE	8	
RESERVE	9	
RESERVE	10	
RESERVE	11	

JM PUPITRE G
JM PUPITRE G

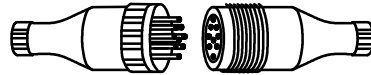

RESERVE		
RESERVE		
RESERVE		
RESERVE		
RESERVE		
21	1	SB3
22	2	SQ3G:2 (NC)
25	3	SB5:13
14	4	SB5:14
8	5	SB5:X1
11	6	SB5:X2
36	7	SB7
RESERVE	8	
RESERVE	9	
RESERVE	10	

JF ELECTROVANNES
JF ELECTROVANNES

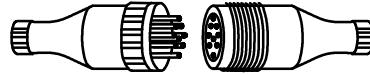

RESERVE		
RESERVE		
RESERVE		
RESERVE		
RESERVE		
RESERVE		
RESERVE		
14	1	
29	2	KA5
1+1	3	RD2:+
2-2	4	RD2:-
RESERVE	5	
36	6	
38	7	KM2
RESERVE	8	

JM ELECTROVANNES
JM ELECTROVANNES

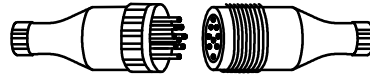

RESERVE		
RESERVE		
RESERVE		
RESERVE		
RESERVE		
RESERVE		
RESERVE		
14	1	SP1:1 (NC)
29	2	SP1:2 (NC)
1+1	3	YV1:A1
2-2	4	YV1:A2
RESERVE	5	
36	6	SP3:1 (NC)
38	7	SP3:2 (NC)
RESERVE	8	

JF MINUTERIE
JF MINUTERIE

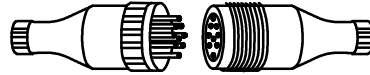

1	1	Fu3
2	2	JF PUPITRE D:1
8	4	
13	3	X1:6
3	5	
44	6	KA6
4	8	
7	7	KA7
5	9	
6	10	KT1:16
	11	KA6
10	12	
11	13	
RESERVE	15	
RESERVE	14	

JM MINUTERIE
JM MINUTERIE

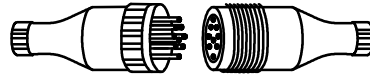

1	1	SB1
2	2	SB1
8	4	SA2:LIA1
13	3	
3	5	SA2
44	6	SA2
4	8	KM2
7	7	SA2
5	9	KM3
6	10	
	11	KM6
10	12	KT4
11	13	KT1:2
RESERVE	15	
RESERVE	14	

520 mm

ARMOIRE
ARMOIRE 520X 530X170

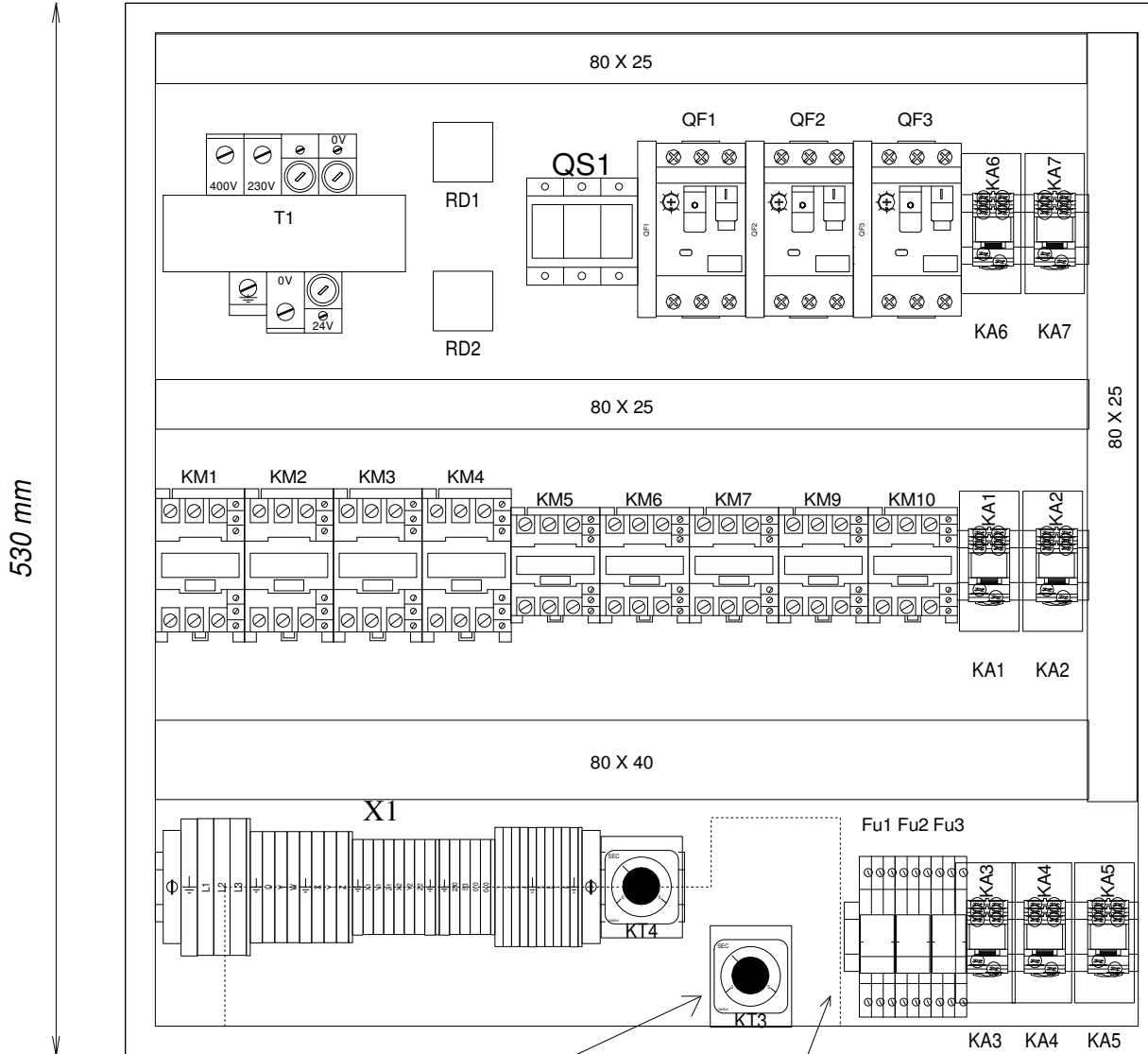

rail din fixé sur le bas d'armoire
afin de fixer KT3

Découpe de la plaque de fond
selon les PE et connecteurs fixés
dans le fond d'armoire

520 mm

260 mm

110 mm

530 mm

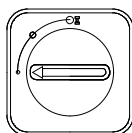

COTE

DERRIERE

520 mm

530 mm

140 mm

70 mm

PG21

50 mm

JF ELECTROVANNES
JF PUPITRE D
JF PUPITRE G

PG16 PG21 PG25 PG29

80 mm

180 mm

30 mm 30 mm 30 mm 40 mm 50 mm 95 mm

SORTIE TORON 0,5 M

JF MINUTERIE

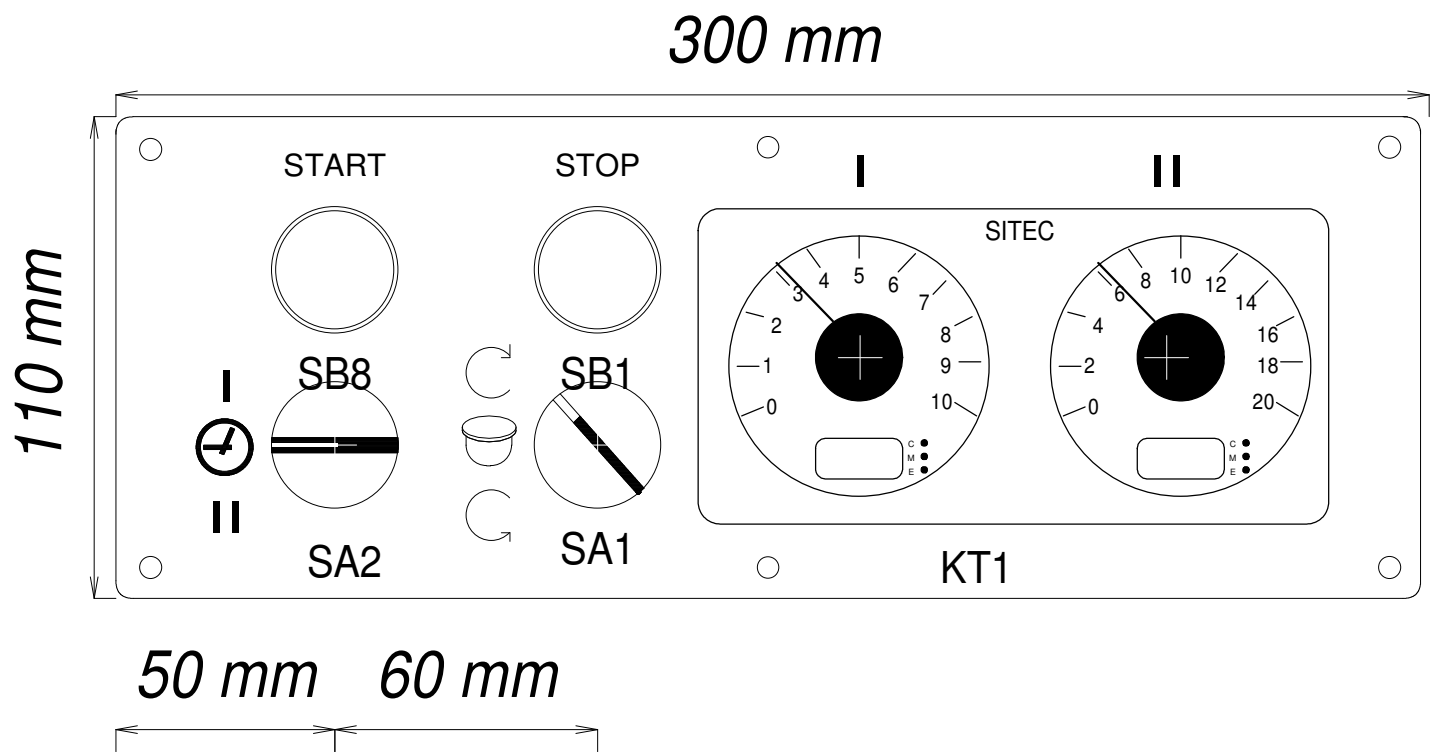

NOTA: longueur du toron = 1.5m

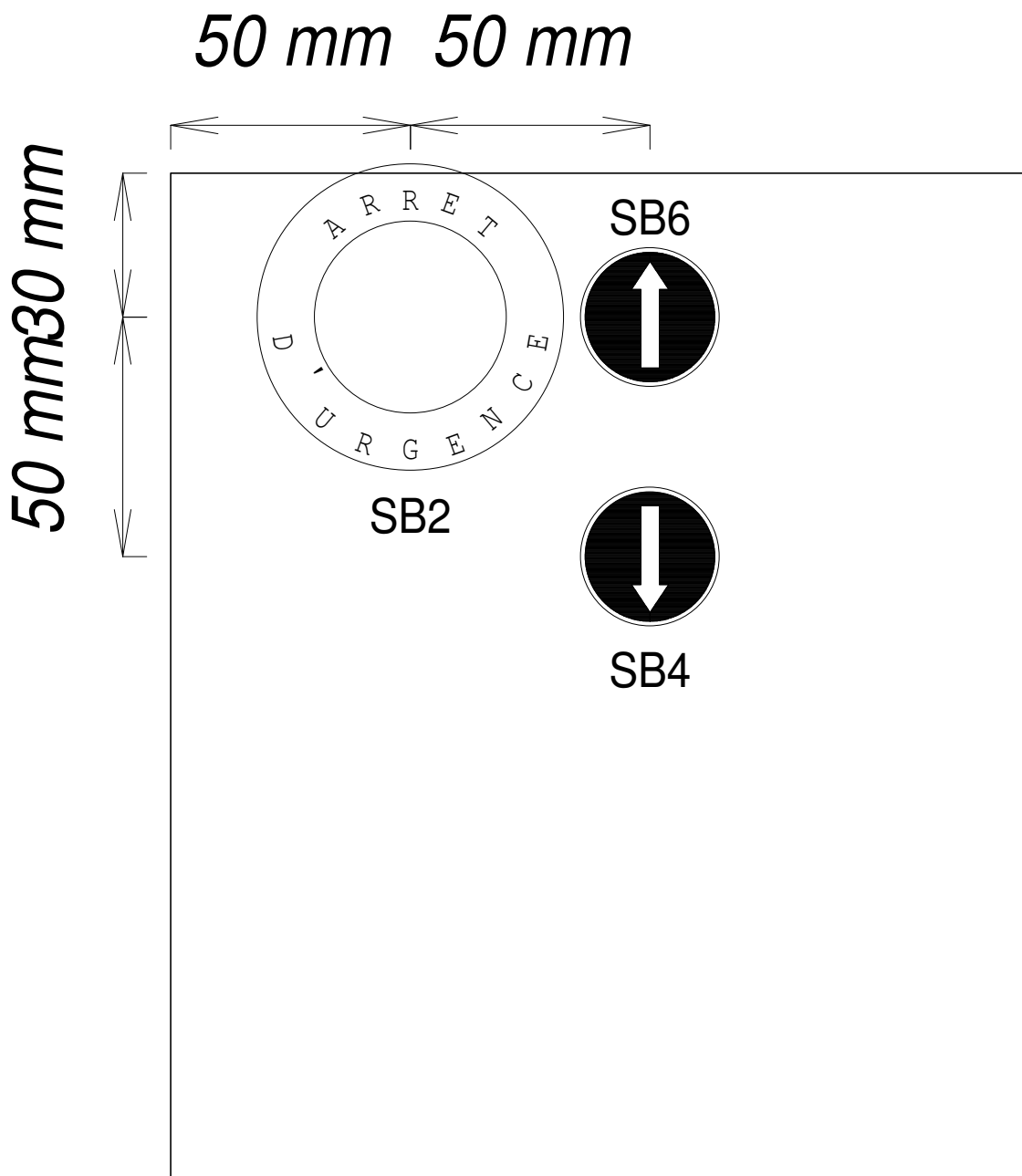

NOTA: longueur du toron = 2m

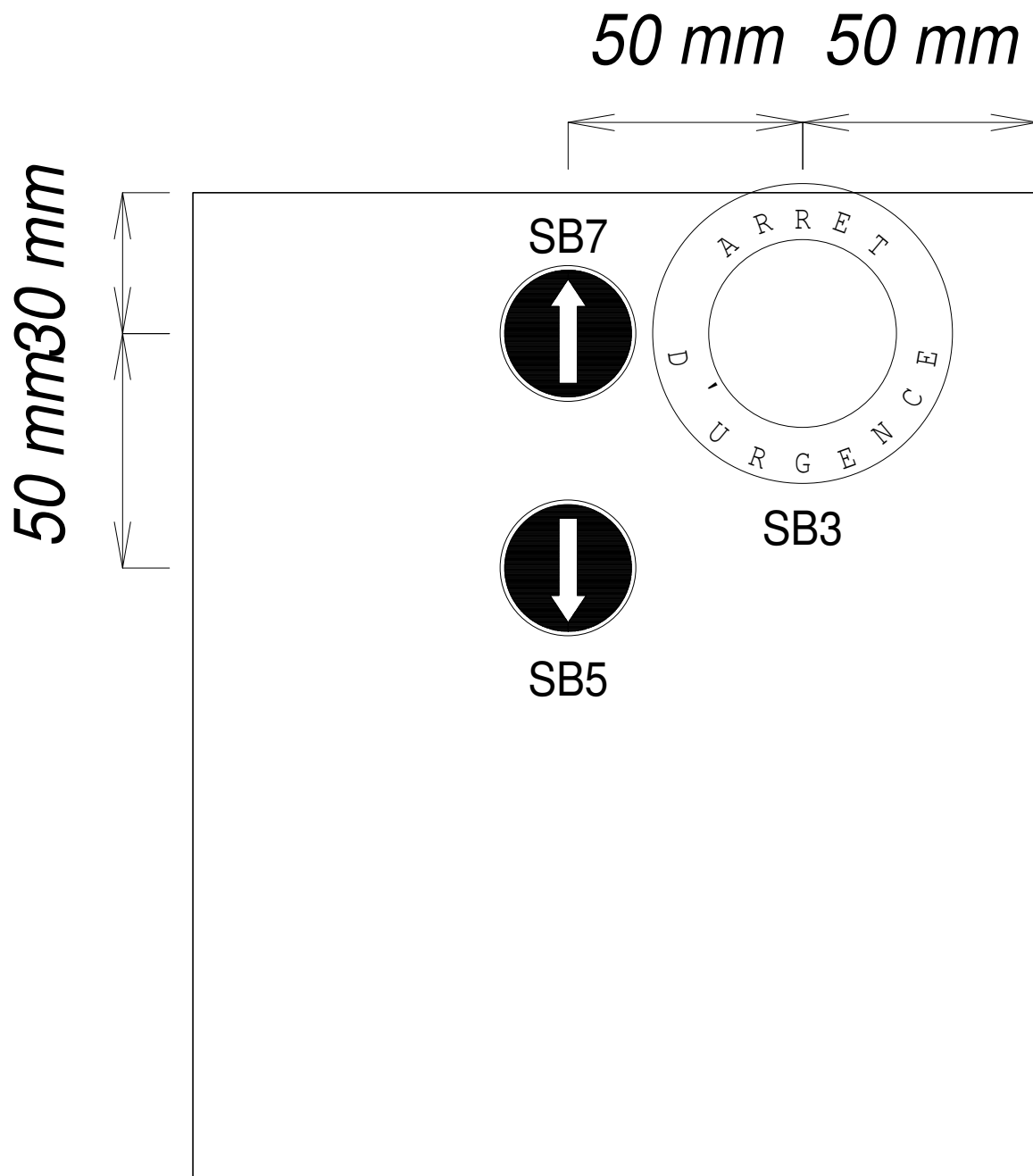

NOTA: longueur du toron = 2m

A
B
C
D
E
F
G
H
I
J
K
L
M
N

1 2 3 4 5 6 7 8 9 10 11 12 13 14 15 16 17 18 19

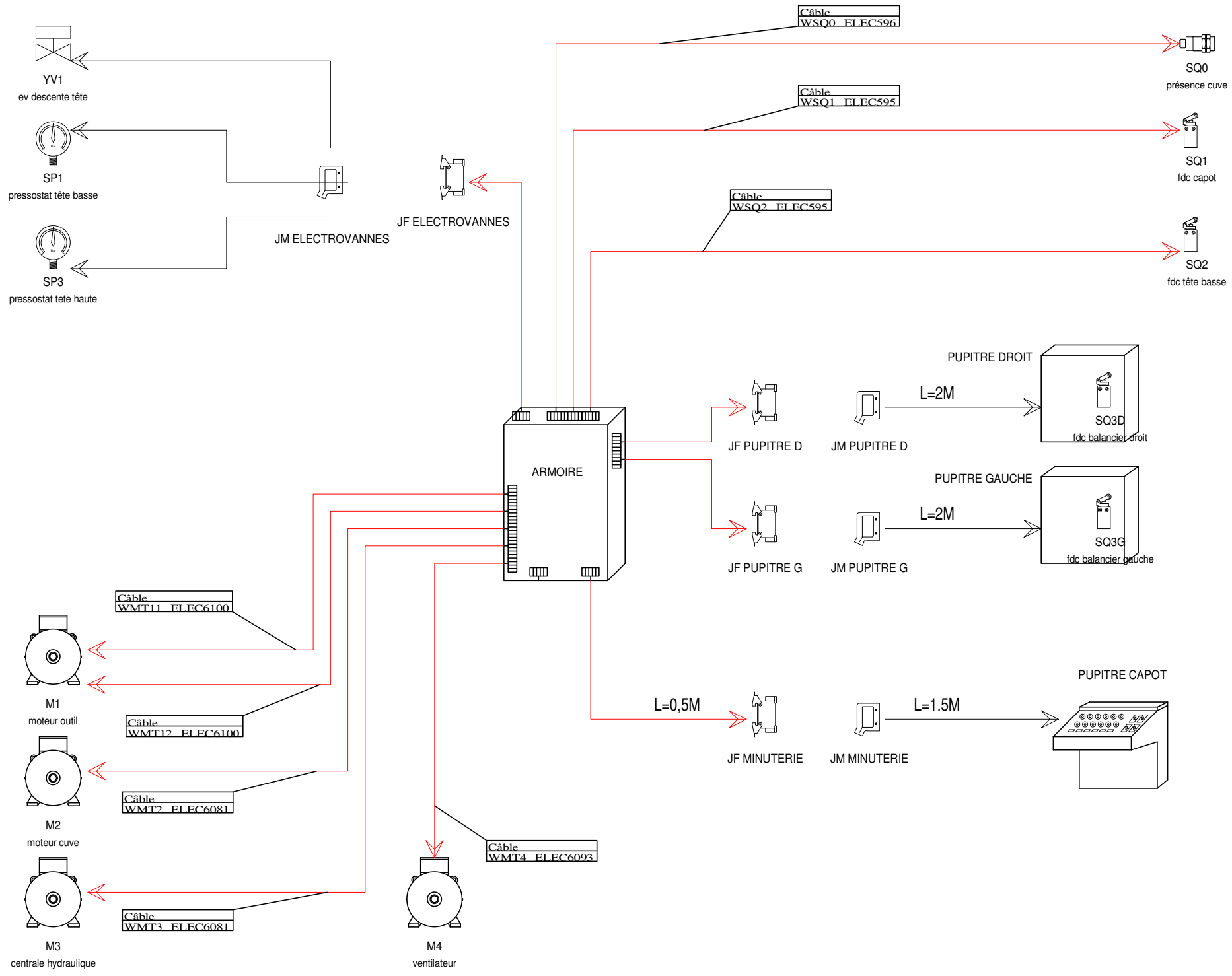

WMI THE MIXING COMPANY
Z.I. Nord 85607 Montaignu Cedex - France
Tél. 33 (0)2 51 45 35 35 - email be-elec@wmi.fr

DOSSIER : MAG R 80 / 120
DESIGN. : SYNOPTIQUE
AG 20 / 23

SCHEMA N° : E01056
DES. PAR : OF
INDICE : A
LE : 16/01/2013
19 21

NOMENCLATURE DÉTAILLÉE

LOCALIS.	REPÈRE	CODE	DÉSIGNATION	FABRICANT	REFERENCE	LIBELLÉ 1	QTÉ	FOLIO
ARMOIRE	ARMOIRE	138004	ARMOIRE 520X 530X170	BERTO	?	Armoire spé. CEB (fabricant italien)	1	14-
		ELEC159	RAIL OMEGA	LEGRAND	37404	EN LONGUEUR DE 3 METRES	1	14-
		ELEC159R	GOULOTTE 80X 40MM (CE, UL ,CSA)	TEHALIT	BA7/80040		1	14-
		ELEC159Y	GOULOTTE 80X 25MM (CE, UL ,CSA)	TEHALIT	BA7/80025		1	14-
	Fu1	ELEC081D	CARTOUCHE 10X38 4A GL	LEGRAND	13304		1	03-4
		ELEC205P	PORTE FUSIBLE 10X38MM 1P	ITALWEBER	K2215		1	03-4
	Fu2	ELEC0824	CARTOUCHE 10X38 10A GL	LEGRAND	13310		1	03-5
		ELEC205P	PORTE FUSIBLE 10X38MM 1P	ITALWEBER	K2215		1	03-5
	Fu3	ELEC0824	CARTOUCHE 10X38 10A GL	LEGRAND	13310		1	03-3
		ELEC205P	PORTE FUSIBLE 10X38MM 1P	ITALWEBER	K2215		1	03-3
	KA1	ELEC2062	RELAIS INTERFACE 24VAC 2RT 10A	FINDER	553280240054		1	04-4
		ELEC2063	SOCLE RELAIS INTERFACE 2RT	FINDER	9472	POUR RELAIS 55.32	1	04-4
	KA2	ELEC2062	RELAIS INTERFACE 24VAC 2RT 10A	FINDER	553280240054		1	04-14
		ELEC2063	SOCLE RELAIS INTERFACE 2RT	FINDER	9472	POUR RELAIS 55.32	1	04-14
	KA3	ELEC2062	RELAIS INTERFACE 24VAC 2RT 10A	FINDER	553280240054		1	05-19
		ELEC2063	SOCLE RELAIS INTERFACE 2RT	FINDER	9472	POUR RELAIS 55.32	1	05-19
	KA4	ELEC2062	RELAIS INTERFACE 24VAC 2RT 10A	FINDER	553280240054		1	04-5
		ELEC2063	SOCLE RELAIS INTERFACE 2RT	FINDER	9472	POUR RELAIS 55.32	1	04-5
	KA5	ELEC2064	RELAIS INTERFACE 24VAC 4RT 7A	FINDER	553480240054		1	04-17
		ELEC2065	SOCLE RELAIS INTERFACE 4RT	FINDER	9474	POUR RELAIS 55.34	1	04-17
	KA6	ELEC2064	RELAIS INTERFACE 24VAC 4RT 7A	FINDER	553480240054		1	05-4
		ELEC2065	SOCLE RELAIS INTERFACE 4RT	FINDER	9474	POUR RELAIS 55.34	1	05-4
	KA7	ELEC2064	RELAIS INTERFACE 24VAC 4RT 7A	FINDER	553480240054		1	05-5
		ELEC2065	SOCLE RELAIS INTERFACE 4RT	FINDER	9474	POUR RELAIS 55.34	1	05-5
	KM1	ELEC100F	CONTACTEUR 24VAC 18A 1'F' 1'O'	SCHNEIDER ELECTRIC	LC1D18B7	TESYS	1	05-12
	KM2	ELEC0404	BLOC ADDITIF 2'F' 2'O'	SCHNEIDER ELECTRIC	LADN22	TESYS	1	05-10
		ELEC100F	CONTACTEUR 24VAC 18A 1'F' 1'O'	SCHNEIDER ELECTRIC	LC1D18B7	TESYS	1	05-10
	KM3	ELEC0402	BLOC ADDITIF 1'F' 1'O'	SCHNEIDER ELECTRIC	LADN11	TESYS	1	05-8



Z.I. Nord 85607 Montaignu Cedex - France

Tel. 33 (0)2 51 45 35 35 - email be-elec@vmi.fr

AG

DOSSIER : MAG R 80 / 120

DESIGN : NOMENCLATURE DÉTAILLÉE

21 / 23

SCHEMA N° : E01056

DES. PAR : OF

INDICE : A

LE : 16/01/2013

◀20 22▶

NOMENCLATURE DÉTAILLÉE

LOCALIS.	REPÈRE	CODE	DÉSIGNATION	FABRICANT	REFERENCE	LIBELLÉ 1	QTÉ	FOLIO
		ELEC100E	CONTACTEUR 24VAC 12A 1'F' 1'O'	SCHNEIDER ELECTRIC	LC1D12B7	TESYS	1	05-8
	KM4	ELEC100F	CONTACTEUR 24VAC 18A 1'F' 1'O'	SCHNEIDER ELECTRIC	LC1D18B7	TESYS	1	05-7
	KM5	ELEC102Q	CONTACTEUR 9A 1'O'	TELEMECANIQUE	LC1K0901B7	MINI CONTACTEUR	1	05-14
		ELEC110W	BLOC ADDITIF 2'O'	TELEMECANIQUE	LA1KN02	POUR MINI CONTACTEUR	1	05-14
	KM6	ELEC102Q	CONTACTEUR 9A 1'O'	TELEMECANIQUE	LC1K0901B7	MINI CONTACTEUR	1	05-16
		ELEC110W	BLOC ADDITIF 2'O'	TELEMECANIQUE	LA1KN02	POUR MINI CONTACTEUR	1	05-16
	KM7	ELEC102Q	CONTACTEUR 9A 1'O'	TELEMECANIQUE	LC1K0901B7	MINI CONTACTEUR	1	04-15
	KM9	ELEC102Q	CONTACTEUR 9A 1'O'	TELEMECANIQUE	LC1K0901B7	MINI CONTACTEUR	1	04-10
	KM10	ELEC102Q	CONTACTEUR 9A 1'O'	TELEMECANIQUE	LC1K0901B7	MINI CONTACTEUR	1	04-9
	KT3	ELEC110I	SUPPORT AVEC BORNES A VIS	FINDER	9026	2INV 10A POUR SERIE 88	1	04-6
		ELEC212K	RELAIS TEMPO. 24VAC/DC	CDC	TN80/749 F01	TN80490136600	1	04-6
	KT4	ELEC110I	SUPPORT AVEC BORNES A VIS	FINDER	9026	2INV 10A POUR SERIE 88	1	05-18
		ELEC212K	RELAIS TEMPO. 24VAC/DC	CDC	TN80/749 F01	TN80490136600	1	05-18
	QF1	ELEC205J	BLOC ADDITIF LATERAL F+O	SCHNEIDER ELECTRIC	GVAN11		1	02-5
		ELEC2721	DISJONCT. MOT. MAG. TH. 17 ... 23A	SCHNEIDER ELECTRIC	GV2ME21	TESYS	1	02-5
	QF2	ELEC205J	BLOC ADDITIF LATERAL F+O	SCHNEIDER ELECTRIC	GVAN11		1	02-12
		ELEC2707	DISJONCT. MOT. MAG. TH. 1,6 ... 2,5A	SCHNEIDER ELECTRIC	GV2ME07	TESYS	1	02-12
	QF3	ELEC205J	BLOC ADDITIF LATERAL F+O	SCHNEIDER ELECTRIC	GVAN11		1	02-16
		ELEC2707	DISJONCT. MOT. MAG. TH. 1,6 ... 2,5A	SCHNEIDER ELECTRIC	GV2ME07	TESYS	1	02-16
	QS1	ELEC136Q	SECTIONNEUR INTER.TRI. 32A	ILME	ZQE 323	TERRE	1	02-3
		ELEC139Q	ACCESSOIRE SECTIONNEUR	ILME	ZR3280	Associé à ZQE XX3	1	02-3
	RD1	ELEC108Q	REDRESSEUR SKB 2504 25A	SEMIKRON	25A400V	PONT DE DIODE 25A 400V CARRE	1	03-11
	RD2	ELEC108Q	REDRESSEUR SKB 2504 25A	SEMIKRON	25A400V	PONT DE DIODE 25A 400V CARRE	1	04-7
	T1	ELEC127Q	TRANSFO 520VA	ITALWEBER	CFM005201828	0.230.400V / 0-12.0-24.24-0-24	1	03-4
JF ELECTROVANNES	JF ELECTROVANNES	ELEC209I	CONNECTEUR FEMELLE	MOLEX	03091152		1	-
		ELEC209K	CONTACT FEMELLE ÉTAMÉ	MOLEX	AWG14/20, série 1189		6	-
JF MINUTERIE	JF MINUTERIE	ELEC209H	CONNECTEUR MALE	MOLEX	03092151		1	-
		ELEC209J	CONTACT MALE ÉTAMÉ	MOLEX	AWG14/20, série 1190		13	-



Z.I. Nord 85607 Montaignu Cedex - France

Tél. 33 (0)2 51 45 35 35 - email be-elec@vmi.fr

AG

DOSSIER : MAG R 80 / 120

DESIGN. : NOMENCLATURE DÉTAILLÉE

22 / 23

SCHEMA N° : E01056

DES. PAR : OF

INDICE : A

LE : 16/01/2013

21

23

NOMENCLATURE DÉTAILLÉE

LOCALIS.	REPÈRE	CODE	DÉSIGNATION	FABRICANT	REFERENCE	LIBELLÉ 1	QTÉ	FOLIO
JF PUPITRE D	JF PUPITRE D	ELEC209I	CONNECTEUR FEMELLE	MOLEX	03091152		1	-
		ELEC209K	CONTACT FEMELLE ÉTAMÉ	MOLEX	AWG14/20, série 1189		10	-
JF PUPITRE G	JF PUPITRE G	ELEC209I	CONNECTEUR FEMELLE	MOLEX	03091152		1	-
		ELEC209K	CONTACT FEMELLE ÉTAMÉ	MOLEX	AWG14/20, série 1189		9	-
JM ELECTROVANNES	JM ELECTROVANNES	ELEC209H	CONNECTEUR MALE	MOLEX	03092151		1	-
		ELEC209J	CONTACT MALE ÉTAMÉ	MOLEX	AWG14/20, série 1190		6	-
JM MINUTERIE	JM MINUTERIE	ELEC209H	CONNECTEUR MALE	MOLEX	03092151		1	-
		ELEC209J	CONTACT MALE ÉTAMÉ	MOLEX	AWG14/20, série 1190		13	-
JM PUPITRE D	JM PUPITRE D	ELEC209H	CONNECTEUR MALE	MOLEX	03092151		1	-
		ELEC209J	CONTACT MALE ÉTAMÉ	MOLEX	AWG14/20, série 1190		10	-
JM PUPITRE G	JM PUPITRE G	ELEC209H	CONNECTEUR MALE	MOLEX	03092151		1	-
		ELEC209J	CONTACT MALE ÉTAMÉ	MOLEX	AWG14/20, série 1190		9	-
PUPITRE CAPOT	KT1	159272	TOLE POUR SERIGRAPHIE 239072	BERTO	?	Plan CAO BVB159272	1	05-7
		ELEC107A	CONNECTEUR FEMELLE 10PTS	PHOENIX CONTACT	1757093	FRONT MSTB 2.5/10-ST-5.08	2	05-7
		ELEC207P	MINUTERIE DOUBLE 24VAC 72x144	SITEC	TIM.72.024.12.DD.GEN.01	affichage digitale (BVBE00981)	1	05-7
		ELEC208A	FIXATION MINUTERIE SITEC	SITEC	?	code BERTO ?	1	05-7
		ELEC208B	SERIGRAPHIE DOUBLE MINUTERIE 72x144	BERTO	?	code BERTO 239072	1	05-7
	SA1	ELEC032N	CORPS BOUTON 1»O»	SCHNEIDER ELECTRIC	ZB5AZ102	HARMONY STYLE 5 (PLASTIQUE)	1	05-9
		ELEC0570	TETE BT 2 POS FIXES MANETTE NOIRE	SCHNEIDER ELECTRIC	ZB5AD2	HARMONY STYLE 5 (PLASTIQUE)	1	05-9
	SA2	ELEC052C	CORPS BOUTON 2»F»	SCHNEIDER ELECTRIC	ZB5AZ103	HARMONY STYLE 5 (PLASTIQUE)	1	05-4
		ELEC0572	TETE BT 3 POS FIXES MANETTE NOIRE	SCHNEIDER ELECTRIC	ZB5AD3	HARMONY STYLE 5 (PLASTIQUE)	1	05-4
		ELEC074B	ELEMENT DE CONTACT 1»O»	SCHNEIDER ELECTRIC	ZBE102	HARMONY STYLE 5 (PLASTIQUE)	2	05-4
	SB1	ELEC032N	CORPS BOUTON 1»O»	SCHNEIDER ELECTRIC	ZB5AZ102	HARMONY STYLE 5 (PLASTIQUE)	1	04-2
		ELEC032P	CAPUCHON D'ETANCHEITE POUR BP SIMPLE	SCHNEIDER ELECTRIC	ZBP0A	HARMONY STYLE 5	1	04-2
		ELEC128I	TETE BP NOIR DEPASSANT MARQUAGE »O»	SCHNEIDER ELECTRIC	ZB5AL232	HARMONY STYLE 5 (PLASTIQUE)	1	04-2
	SB8	ELEC032P	CAPUCHON D'ETANCHEITE POUR BP SIMPLE	SCHNEIDER ELECTRIC	ZBP0A	HARMONY STYLE 5	1	05-4
		ELEC052C	CORPS BOUTON 2»F»	SCHNEIDER ELECTRIC	ZB5AZ103	HARMONY STYLE 5 (PLASTIQUE)	1	05-4
		ELEC103I	TETE BP BLANC AFFLEURANT	SCHNEIDER ELECTRIC	ZB5AA1	HARMONY STYLE 5 (PLASTIQUE)	1	05-4



Z.I. Nord 85607 Montaignu Cedex - France

Tél. 33 (0)2 51 45 35 35 - email be-elec@vmi.fr

AG

DOSSIER : MAG R 80 / 120

DESIGN : NOMENCLATURE DÉTAILLÉE

23 / 23

SCHEMA N° : E01056

DES. PAR : OF

INDICE : A

LE : 16/01/2013

◀22

24▶

NOMENCLATURE DÉTAILLÉE

LOCALIS.	REPÈRE	CODE	DÉSIGNATION	FABRICANT	REFERENCE	LIBELLÉ 1	QTÉ	FOLIO
PUPITRE DROIT	SB2	ELEC032N	CORPS BOUTON 1»O»	SCHNEIDER ELECTRIC	ZB5AZ102	HARMONY STYLE 5 (PLASTIQUE)	1	04-2
		ELEC055C	TETE BP A.U. ACC ROUGE Ø40MM	SCHNEIDER ELECTRIC	ZB5AS844	HARMONY STYLE 5 (PLASTIQUE)	1	04-2
		ELEC074A	ELEMENT DE CONTACT 1»F»	SCHNEIDER ELECTRIC	ZBE101	HARMONY STYLE 5 (PLASTIQUE)	1	04-2
		ELEC203F	ETIQUETTE AVEC TEXTE A.U. EN ANGLAIS	SCHNEIDER ELECTRIC	ZBY9330	HARMONY	1	04-2
		ELEC203F	ETIQUETTE AVEC TEXTE A.U. EN ANGLAIS	SCHNEIDER ELECTRIC	ZBY9330	HARMONY	1	04-2
	SB4	ELEC032P	CAPUCHON D'ETANCHEITE POUR BP SIMPLE	SCHNEIDER ELECTRIC	ZBP0A	HARMONY STYLE 5	1	04-6
		ELEC052P	CORPS VOYANT LUM A LED BLANCHE	SCHNEIDER ELECTRIC	ZB5AVB1	HARMONY STYLE 5 (PLASTIQUE)	1	04-6
		ELEC074A	ELEMENT DE CONTACT 1»F»	SCHNEIDER ELECTRIC	ZBE101	HARMONY STYLE 5 (PLASTIQUE)	1	04-6
		ELEC128Q	TETE BP LUMINEUX BLANC	SCHNEIDER ELECTRIC	ZB5AA18	HARMONY STYLE 5 (PLASTIQUE)	1	04-6
	SB6	ELEC032P	CAPUCHON D'ETANCHEITE POUR BP SIMPLE	SCHNEIDER ELECTRIC	ZBP0A	HARMONY STYLE 5	1	04-17
		ELEC052B	CORPS BOUTON 1»F»	SCHNEIDER ELECTRIC	ZB5AZ101	HARMONY STYLE 5 (PLASTIQUE)	1	04-17
		ELEC055G	TETE BP NOIR DESCENTE	SCHNEIDER ELECTRIC	ZB5AA335		1	04-17
PUPITRE GAUCHE	SB3	ELEC032N	CORPS BOUTON 1»O»	SCHNEIDER ELECTRIC	ZB5AZ102	HARMONY STYLE 5 (PLASTIQUE)	1	04-2
		ELEC055C	TETE BP A.U. ACC ROUGE Ø40MM	SCHNEIDER ELECTRIC	ZB5AS844	HARMONY STYLE 5 (PLASTIQUE)	1	04-2
		ELEC074A	ELEMENT DE CONTACT 1»F»	SCHNEIDER ELECTRIC	ZBE101	HARMONY STYLE 5 (PLASTIQUE)	1	04-2
		ELEC203F	ETIQUETTE AVEC TEXTE A.U. EN ANGLAIS	SCHNEIDER ELECTRIC	ZBY9330	HARMONY	1	04-2
	SB5	ELEC032P	CAPUCHON D'ETANCHEITE POUR BP SIMPLE	SCHNEIDER ELECTRIC	ZBP0A	HARMONY STYLE 5	1	04-8
		ELEC052P	CORPS VOYANT LUM A LED BLANCHE	SCHNEIDER ELECTRIC	ZB5AVB1	HARMONY STYLE 5 (PLASTIQUE)	1	04-8
		ELEC074A	ELEMENT DE CONTACT 1»F»	SCHNEIDER ELECTRIC	ZBE101	HARMONY STYLE 5 (PLASTIQUE)	1	04-8
		ELEC128Q	TETE BP LUMINEUX BLANC	SCHNEIDER ELECTRIC	ZB5AA18	HARMONY STYLE 5 (PLASTIQUE)	1	04-8
	SB7	ELEC032P	CAPUCHON D'ETANCHEITE POUR BP SIMPLE	SCHNEIDER ELECTRIC	ZBP0A	HARMONY STYLE 5	1	04-18
		ELEC052B	CORPS BOUTON 1»F»	SCHNEIDER ELECTRIC	ZB5AZ101	HARMONY STYLE 5 (PLASTIQUE)	1	04-18
		ELEC055G	TETE BP NOIR DESCENTE	SCHNEIDER ELECTRIC	ZB5AA335		1	04-18
								-
								-
								-
								-

Z.I. Nord 85607 Montaignu Cedex - France

Tél. 33 (0)2 51 45 35 35 - email be-elec@vni.fr

AG

DOSSIER : MAG R 80 / 120

DESIGN : NOMENCLATURE DÉTAILLÉE

24 / 23

SCHEMA N° : E01056

DES. PAR : OF

INDICE : A

LE : 16/01/2013

◀23

▶

NOMENCLATURE CUMULÉE

ACHAT	CODE	DÉSIGNATION	FABRICANT	REFERENCE	LIBELLÉ 1	QUANTITÉ
CABEUR	138004	ARMOIRE 520X 530X170	BERTO	?	Armoire spé. CEB (fabricant italien)	1
	159272	TOLE POUR SERIGRAPHIE 239072	BERTO	?	Plan CAO BVB159272	1
	ELEC208B	SERIGRAPHIE DOUBLE MINUTERIE 72x144	BERTO	?	code BERTO 239072	1
	ELEC212K	RELAIS TEMPO. 24VAC/DC	CDC	TN80/749 F01	TN80490136600	2
	ELEC2062	RELAIS INTERFACE 24VAC 2RT 10A	FINDER	553280240054		4
	ELEC2064	RELAIS INTERFACE 24VAC 4RT 7A	FINDER	553480240054		3
	ELEC110I	SUPPORT AVEC BORNES A VIS	FINDER	9026	2INV 10A POUR SERIE 88	2
	ELEC2063	SOCLE RELAIS INTERFACE 2RT	FINDER	9472	POUR RELAIS 55.32	4
	ELEC2065	SOCLE RELAIS INTERFACE 4RT	FINDER	9474	POUR RELAIS 55.34	3
	ELEC136Q	SECTIONNEUR INTER.TRI. 32A	ILME	ZQE 323	TERRE	1
	ELEC139Q	ACCESSOIRE SECTIONNEUR	ILME	ZR3280	Associé à ZQE XX3	1
	ELEC127Q	TRANSFO 520VA	ITALWEBER	CFM005201828	0.230.400V / 0-12.0-24.24-0-24	1
	ELEC205P	PORTE FUSIBLE 10X38MM 1P	ITALWEBER	K2215		3
	ELEC081D	CARTOUCHE 10X38 4A GL	LEGRAND	13304		1
	ELEC0824	CARTOUCHE 10X38 10A GL	LEGRAND	13310		2
	ELEC159	RAIL OMEGA	LEGRAND	37404	EN LONGUEUR DE 3 METRES	1
	ELEC209I	CONNECTEUR FEMELLE	MOLEX	03091152		3
	ELEC209H	CONNECTEUR MALE	MOLEX	03092151		5
	ELEC209K	CONTACT FEMELLE ÉTAMÉ	MOLEX	AWG14/20, série 1189		25
	ELEC209J	CONTACT MALE ÉTAMÉ	MOLEX	AWG14/20, série 1190		51
	ELEC107A	CONNECTEUR FEMELLE 10PTS	PHOENIX CONTACT	1757093	FRONT MSTB 2.5/10-ST-5.08	2
	ELEC303T	BUTEE D'EXTREMITE CLIPFIX 35	PHOENIX CONTACT	3022218		2
	ELEC303M	CLOISON TERMINALE 2,5MM² D-ST 2.5	PHOENIX CONTACT	3030417		2
	ELEC303N	CLOISON TERMINALE 4MM² D-ST 4	PHOENIX CONTACT	3030420		1
	ELEC303P	CLOISON TERMINALE 6MM² D-ST 6	PHOENIX CONTACT	3030433		1
	ELEC3049	CLOISON TERMINALE 2,5MM² D-ST-TWIN	PHOENIX CONTACT	3030488		1
	ELEC3047	BLOC JONCTION A 3 RESSORTS 1.5mm² GRIS	PHOENIX CONTACT	3031128	SERIE ST GRISE	8
	ELEC3048	BLOC JONCTION A 3 RESSORTS 1.5mm² V/J	PHOENIX CONTACT	3031144	SERIE ST V/J	2

Z.I. Nord 85607 Montaignu Cedex - France

Tél. 33 (0)2 51 45 35 35 - email be-elec@vni.fr

NOM CUMUL
01 / 03

DOSSIER : MAG R 80 / 120

DESIGN : NOMENCLATURE CUMULÉE

SCHEMA N° : E01056

DES. PAR : OF

INDICE : A

LE : 16/01/2013

02

NOMENCLATURE CUMULÉE

ACHAT	CODE	DÉSIGNATION	FABRICANT	REFERENCE	LIBELLÉ 1	QUANTITÉ
	ELEC303A	BLOC JONCTION A RESSORT 2.5mm², GRIS	PHOENIX CONTACT	3031212	SERIE ST GRISE	10
	ELEC303U	BLOC JONCTION A RESSORT 2.5mm², V/J	PHOENIX CONTACT	3031238	SERIE ST V/J	3
	ELEC303B	BLOC JONCTION A RESSORT 4mm², GRIS	PHOENIX CONTACT	3031364	SERIE ST GRISE	6
	ELEC303G	BLOC JONCTION A RESSORT 4mm², V/J	PHOENIX CONTACT	3031380	SERIE ST V/J	2
	ELEC303C	BLOC JONCTION A RESSORT 6mm², GRIS	PHOENIX CONTACT	3031487	SERIE ST GRISE	3
	ELEC303H	BLOC JONCTION A RESSORT 6mm², V/J	PHOENIX CONTACT	3031500	SERIE ST V/J	1
	ELEC2707	DISJONCT. MOT. MAG. TH. 1,6 ... 2,5A	SCHNEIDER ELECTRIC	GV2ME07	TESYS	2
	ELEC2721	DISJONCT. MOT. MAG. TH. 17 ... 23A	SCHNEIDER ELECTRIC	GV2ME21	TESYS	1
	ELEC205J	BLOC ADDITIF LATERAL F+O	SCHNEIDER ELECTRIC	GVAN11		3
	ELEC0402	BLOC ADDITIF 1'F' 1'O'	SCHNEIDER ELECTRIC	LADN11	TESYS	1
	ELEC0404	BLOC ADDITIF 2'F' 2'O'	SCHNEIDER ELECTRIC	LADN22	TESYS	1
	ELEC100E	CONTACTEUR 24VAC 12A 1'F' 1'O'	SCHNEIDER ELECTRIC	LC1D12B7	TESYS	1
	ELEC100F	CONTACTEUR 24VAC 18A 1'F' 1'O'	SCHNEIDER ELECTRIC	LC1D18B7	TESYS	3
	ELEC103I	TETE BP BLANC AFFLEURANT	SCHNEIDER ELECTRIC	ZB5AA1	HARMONY STYLE 5 (PLASTIQUE)	1
	ELEC128Q	TETE BP LUMINEUX BLANC	SCHNEIDER ELECTRIC	ZB5AA18	HARMONY STYLE 5 (PLASTIQUE)	2
	ELEC055G	TETE BP NOIR DESCENTE	SCHNEIDER ELECTRIC	ZB5AA335		2
	ELEC0570	TETE BT 2 POS FIXES MANETTE NOIRE	SCHNEIDER ELECTRIC	ZB5AD2	HARMONY STYLE 5 (PLASTIQUE)	1
	ELEC0572	TETE BT 3 POS FIXES MANETTE NOIRE	SCHNEIDER ELECTRIC	ZB5AD3	HARMONY STYLE 5 (PLASTIQUE)	1
	ELEC128I	TETE BP NOIR DEPASSANT MARQUAGE »O»	SCHNEIDER ELECTRIC	ZB5AL232	HARMONY STYLE 5 (PLASTIQUE)	1
	ELEC055C	TETE BP A.U. ACC ROUGE Ø40MM	SCHNEIDER ELECTRIC	ZB5AS844	HARMONY STYLE 5 (PLASTIQUE)	2
	ELEC052P	CORPS VOYANT LUM A LED BLANCHE	SCHNEIDER ELECTRIC	ZB5AVB1	HARMONY STYLE 5 (PLASTIQUE)	2
	ELEC052B	CORPS BOUTON 1»F»	SCHNEIDER ELECTRIC	ZB5AZ101	HARMONY STYLE 5 (PLASTIQUE)	2
	ELEC032N	CORPS BOUTON 1»O»	SCHNEIDER ELECTRIC	ZB5AZ102	HARMONY STYLE 5 (PLASTIQUE)	4
	ELEC052C	CORPS BOUTON 2»F»	SCHNEIDER ELECTRIC	ZB5AZ103	HARMONY STYLE 5 (PLASTIQUE)	2
	ELEC074A	ELEMENT DE CONTACT 1»F»	SCHNEIDER ELECTRIC	ZBE101	HARMONY STYLE 5 (PLASTIQUE)	4
	ELEC074B	ELEMENT DE CONTACT 1»O»	SCHNEIDER ELECTRIC	ZBE102	HARMONY STYLE 5 (PLASTIQUE)	2
	ELEC032P	CAPUCHON D'ETANCHEITE POUR BP SIMPLE	SCHNEIDER ELECTRIC	ZBP0A	HARMONY STYLE 5	6
	ELEC203F	ETIQUETTE AVEC TEXTE A.U. EN ANGLAIS	SCHNEIDER ELECTRIC	ZBY9330	HARMONY	3



Z.I. Nord 85607 Montaignu Cedex - France

Tél. 33 (0)2 51 45 35 35 - email be-elec@vmi.fr

NOM CUMUL
02 / 03

DOSSIER : MAG R 80 / 120

DESIGN : NOMENCLATURE CUMULÉE

SCHEMA N° : E01056

DES. PAR : OF

INDICE : A

LE : 16/01/2013

◀01 03▶

