

INSTRUCTION AND MAINTENANCE MANUAL

MODEL: MAG 80 2 V

SPIRAL DOUGH KNEADING MACHINE WITH FIXED BOWL

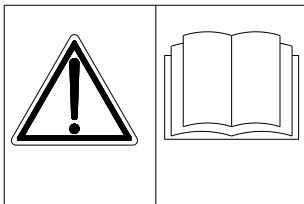
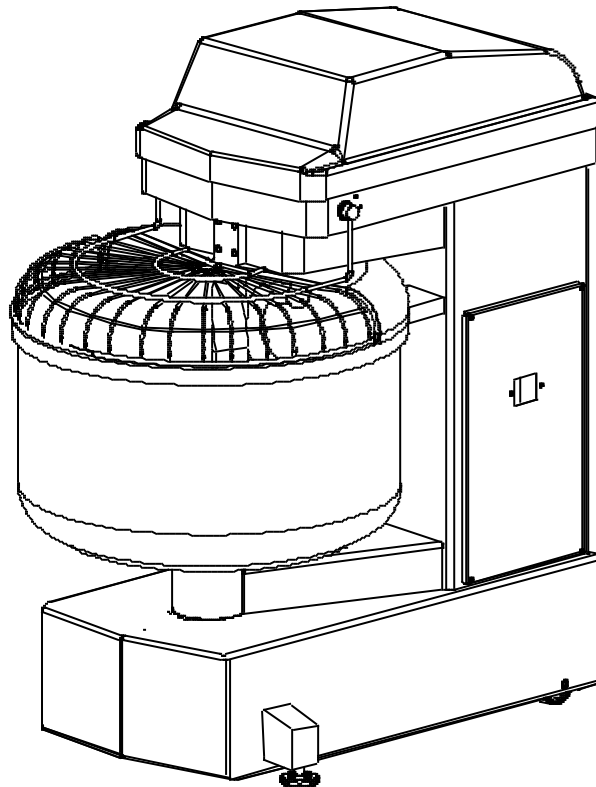

This instruction and maintenance manual forms an integral part of the machine; it must be preserved for the full life of the machine and must be passed on to any subsequent users.

The manual contains all the instructions necessary for the transport, installation, start-up, use, maintenance and disposal of the machine and must therefore be read and understood before proceeding with any of these operations. It must be handled with care and stored where it is readily available for consultation both by the machine operators and

the technicians. The observance of the contents of the manual ensures the safe, correct and optimal operation of the machine itself, as well as the safety of the machine operator and other persons authorised to come into contact with the machine.

MACHINE SPECIFICATION SHEET

Article number:	P01530
Machine Description:	SPIRAL MIXER WITH FIXED BOWL 80 MAG 400V/50HZ 3PH 2V WITH DIGITAL TIMERS 72X144 AND STAINLESS STEEL GRID
Serial number:	165548-49-50
Year of construction:	2012
Number of speeds:	2
Voltage (V):	400
Frequency (Hz):	50
Number of phases:	3
Total power absorbed (kW):	5,25
Total current absorbed (A):	10,59
Characteristics of the power cable:	FG07 4G 2,5 L 3,5
Characteristics of the branch circuit breaker device: (N.B.: buyer is responsible for installation)	
Conformity:	CE
Manufacturer:	VMI S.A. ZONE INDUSTRIELLE NORD 85607 MONTAIGU CEDEX FRANCE TEL.: +33 2 51453535 FAX: +33 2 51064084

CONTENTS

1	SYMBOLS AND PERSONNEL QUALIFICATIONS	5
2	IDENTIFICATION OF THE MACHINE	7
	<i>Machine conforming to CE standards</i>	7
	<i>Machine conforming to ETL standards</i>	7
3	SAFETY INSTRUCTIONS	8
	<i>Safety measures</i>	8
	<i>Safety devices</i>	8
	<i>Accident prevention</i>	9
	<i>Machine tests carried out by the manufacturer</i>	9
4	RISKS, PROHIBITIONS, OBLIGATIONS	10
5	DESCRIPTION OF THE MACHINE AND ITS USE	11
	<i>Intended use of the machine</i>	11
	<i>Percentages of ingredients</i>	11
	<i>Machine structure</i>	11
	<i>General machine operation</i>	12
6	PRESERVATION OF THE MACHINE	13
	<i>Preservation of the machine before a long period of disuse</i>	13
	<i>Storage of the packed machine</i>	13
	<i>Storage of the unpacked machine</i>	13
7	UNPACKING THE MACHINE	14
8	HANDLING THE MACHINE	15
	<i>Lifting the packed machine (by means of a fork lift truck or transpallet)</i>	15
	<i>Lifting the unpacked machine (by means of a belt)</i>	15
	<i>Moving the unpacked machine manually</i>	16
9	INSTALLATION OF THE MACHINE AND POSITION OF THE OPERATOR	17
	<i>Operating conditions</i>	17
	<i>Position of the machine and of the operator</i>	17
	<i>Fixing the machine in place</i>	18
10	ELECTRICAL SYSTEM	19
	<i>Connection to the power supply</i>	19
	<i>Disconnecting the machine supplied with plug attachment from the power supply</i>	19
11	CLEANING THE MACHINE	20
	<i>Cleaning the body of the machine</i>	20
	<i>Cleaning the inside of the bowl and the mixing tools</i>	20
	<i>Cleaning the surface underneath the machine</i>	20
12	OPERATING PROCEDURES	21
	<i>Preliminary machine check-up</i>	21
	<i>Loading the ingredients to be kneaded</i>	21
	<i>Executing a work cycle</i>	21
	<i>Warnings relative to repeated interruptions of a work cycle</i>	22
	<i>Stopping the machine</i>	22
	<i>Unloading the kneaded dough</i>	22
13	PERIODICAL INSPECTIONS, CLEANING AND MAINTENANCE OF THE MACHINE	23
	<i>Cleaning procedures and periodical inspections</i>	23
	<i>Inspection of the safety devices</i>	23
	<i>WEEKLY, MONTHLY, ANNUAL Maintenance procedures</i>	25
	<i>Adjustment of the belt tension and replacement of the transmission belts</i>	26
14	TROUBLE SHOOTING	27
15	DISASSEMBLING AND DISPOSING OF THE MACHINE	28

APPENDICES

Appendix 1	The control panel and programming of a work cycle
Appendix 2	Technical characteristics and packaging
Appendix 3	Adjustment of the tension of the transmission belts
Appendix 4	Wiring diagrams
Appendix 5	Exploded view of the machine and parts list

N.B.



(i) The technical data is not binding. The data can be changed in order to improve the product.

(ii) Drawings and illustrations are only indicative.

1 SYMBOLS AND PERSONNEL QUALIFICATIONS



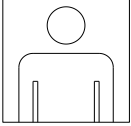

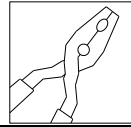
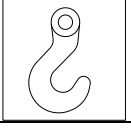
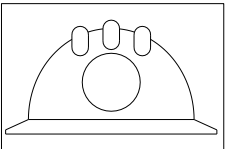
The person responsible for safety in the company and in the production department, when selecting the personnel to operate the machine, must select someone suitable for the job according to local law and must, furthermore, take into consideration the person's training, physical and psychological conditions (stability, sense of responsibility, etc.). Furthermore, once selected, the personnel assigned to operate the machine must be suitably trained (based on personal aptitude and capacity), which includes the full comprehension of this manual to ensure that the operator knows the machine, its functions, its behaviour and how to correctly execute each procedure pertinent to the machine operation in absolute safety.

The following table indicates the symbols and corresponding, required qualifications for the personnel operating on the plant, which are used throughout this manual to specify the qualification necessary to implement a specific task.

Symbol	Description	Characteristics/Qualifications
	MACHINE OPERATOR	A person in good health, that has been suitably trained to operate the machine (i.e. that has a good knowledge of: the machine functions, the machine regulations, the safety devices and protections installed on the machine, the possible work cycles, how to program a work cycle, the type of ingredients which can be used, as well as the corresponding maximum quantities allowed). The person must have carefully read and understood this manual for the use and maintenance of the machine.
	ELECTRICAL SERVICE ENGINEER	A person in good health, with the qualification of electrical service engineer, that has carefully read and understood this manual for the use and maintenance of the machine.
	MECHANICAL SERVICE ENGINEER	A person in good health, with the qualification of mechanical service engineer, that has carefully read and understood this manual for the use and maintenance of the machine.
	PERSON RESPONSIBLE FOR MATERIAL/EQUIPMENT HANDLING	A person in good health, qualified to handle loads, that has carefully read and understood this manual for the use and maintenance of the machine.
	CLIENT ASSISTANCE: C/O the manufacturer	Addresses the following requests for: <ul style="list-style-type: none"> • updates of the manual; • telephonic assistance regarding machine functions, start-up and failures; • spare parts; • machine repairs; • system overhaul;

N.B. This machine must not be used/intervened upon by persons with any type of electronic implants (e.g. pacemaker)

The following table indicates the warning and safety labels present on the machine and in this manual, which point out possible dangers related to the machine and/or to a specific task being implemented.

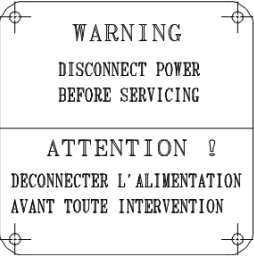
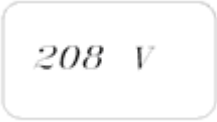
Warning and Safety Label/Symbol	Description
ATTENTION	This type of warning invites the competent person implementing a specific task to pay attention while carrying out the required manoeuvres. Non-observance of this warning can damage the machine and/or injure the persons assigned to the machine.
	This symbol indicates a general state of danger for the personnel assigned to operate on the machine and/or for the machine itself.
	This symbol indicates the presence of live parts. Before carrying out any type of intervention on the machine, interrupt the power supply to the machine by turning off the main switch and ensuring that the electrical panel on the machine and the machine power cable are isolated from the main power supply in a safe manner for the entire duration of the intervention, without accidental risk of re-energising of the power supply !
	This symbol indicates the presence of moving members and, therefore, the risk of entrapment.
	This symbol indicates the risk of being crushed.
	This warning label indicates that the user must disconnect the power before servicing the machine.
	This label indicates the electrical voltage (e.g. 208 V, for this particular example).

2 IDENTIFICATION OF THE MACHINE

Machine conforming to CE standards

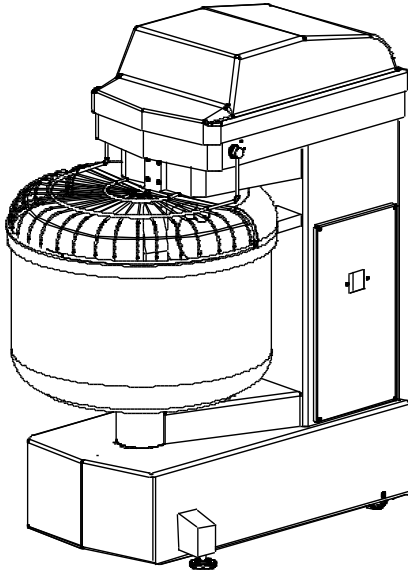

CE	
Model	<input type="text"/>
Serial number	<input type="text"/>
Date of manufacture	<input type="text"/>
Voltage	<input type="text"/> Volts
Frequency	<input type="text"/> Hertz
Number of phases	<input type="text"/>
Total power	<input type="text"/> kW

A serial plate, similar to the one illustrated above, is located at the back of the machine. It specifies:



- the type of conformity (CE)
- the details of the manufacturer
- the type of machine
- the serial number
- the year of construction
- the voltage, frequency and number of phases
- the total power absorbed (kW).

The electrical characteristics (voltage, frequency, number of phases and power absorbed) are specified in this manual under the section “machine specifications” and in Appendix 2, as well as on the motor serial plates.

The weight and dimensions of the machine (with and without packaging) are also specified in this manual (refer to Appendix 2).

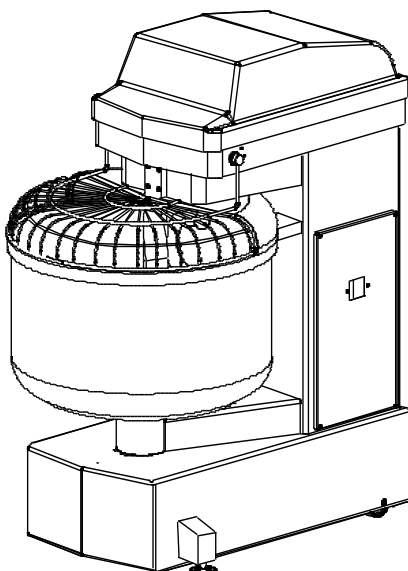
Machine conforming to ETL standards



  	
<small>ETL LISTED ETL LISTED ETL LISTED</small>	
Model	<input type="text"/>
Serial number	<input type="text"/>
Date of manufacture	<input type="text"/>
Voltage	<input type="text"/> Volts
Frequency	<input type="text"/> Hertz
Number of phases	<input type="text"/>
Amperage	<input type="text"/> Amps

A serial plate, similar to the one illustrated above, is located at the back of the machine. It specifies:

- the type of conformity (ETL)
- the details of the manufacturer
- the type of machine
- the serial number
- the year of construction
- the voltage, frequency and number of phases
- the total current absorbed (A).

The electrical characteristics (voltage, frequency, number of phases and current absorbed) are specified in this manual under the section “machine specifications” and in Appendix 2, as well as on the motor serial plates.

The weight and dimensions of the machine (with and without packaging) are also specified in this manual (refer to Appendix 2).

3 SAFETY INSTRUCTIONS

The obligatory safety measures, which must be adopted in order to ensure the safe use of the machine, are listed below. The symbols and signs appearing in the various sections of the manual indicate the qualifications required by the persons assigned to a specific task and the corresponding risk level. The plant manager is personally responsible for the training of suitably qualified personnel assigned to a specific task.

Safety measures

- The space surrounding the machine and related devices must be well illuminated, clear and clean.
- The personnel assigned to operate the machine must be physically well, psychologically stable and must wear suitable clothing (anti-slip safety shoes, close-fitting sleeves with closed shirt cuffs, gloves, mask and safety glasses, as required for the assigned task). It is absolutely forbidden to wear loose-fitting garments, materials or accessories (ties, torn garments, open jackets, loose pieces of materials etc.) to avoid the risk of entrapment.
N.B. This machine must not be used/intervened upon by persons with any type of electronic implants (e.g. pacemaker)
- It is necessary to respect the maximum quantity of dough which can be kneaded for the specific machine, which can vary, depending on the percentages of the ingredients used.
- During maintenance and cleaning operations, the personnel assigned to these tasks must turn off the main switch and disconnect the machine from the electrical supply ensuring that the electrical panel on the machine and the machine power cable are isolated from the main power supply in a safe manner for the entire duration of the intervention, without accidental risk of re-energising of the power supply.
- The service engineer must wear protective clothing suitable for the task to be carried out; clothing which must offer protection against organic, chemical, biological, mechanical and/or electrical risks.
- When working with the machine, it is always necessary to observe the safety warnings and signs on the machine itself, in the work environment and on the products used, which point out, for example:
 - electrical, mechanical or thermal risks
 - the risk of slipping on wet or greasy surfaces
 - the risk of allergies to substances or irritations which can arise from products used in the production process or cleaning procedures.Non-observance of the safety warnings and signs can lead to minor or major injuries.

Safety devices

The machine is equipped with safety devices which protect both the operator and the machine itself. Under no circumstances must they be removed, tampered with or modified in any way. It is necessary to periodically check that they function correctly.

- *Main switch (external)*: Turned off, it interrupts the electrical supply to the machine, permitting maintenance operations to be carried out in absolute safety.
- *Thermal switch (internal)*: It interrupts the electrical supply when the electric motor overheats.
- *Thermal overload switch (internal)*: It interrupts the electrical supply to the motor when excessive electrical current is absorbed.
- *Emergency switch (external)*: It interrupts the electrical supply to the machine, guaranteeing the complete safety of the machine and operator.
- *Fixed protective covers (external)*: All the fixed covers (fastened with screws or mechanical blocks) protect against heat and must not be removed, except by suitably qualified personnel carrying out maintenance operations in the specified manner and according to the safety standards in force. After any maintenance procedures, all the protective covers must be correctly re-positioned and securely fastened, before starting up the machine again.
- *Mobile protective bowl cover (external)*: The opening of the mobile protective bowl cover activates microswitches which interrupt the machine functions and do not allow it to operate unless the mobile protective cover is completely closed.

Note: When one of the safety systems is activated, the time taken for the spiral and bowl rotation to stop is not more than 4 seconds; this time interval is a result of the inertia. An immediate stop would cause stresses and fatigue failures.

Accident prevention

Before starting up the machine:

Read this manual carefully. Ensure no children, animals or unauthorised persons are in the vicinity of the machine. Carefully check that the machine and external safety devices function correctly.

During machine operation:

Never leave the machine unattended. Pay attention to abnormal noises or machine behaviour. Keep away from moving members. Never open the mobile protective cover before the spiral tool has completely stopped rotating.

Upon completion of a work cycle:

Empty the contents of the machine bowl completely. Turn off the main switch and disconnect the machine from the electrical supply ensuring that the electrical panel on the machine and the machine power cable are isolated from the main power supply in a safe manner for the entire duration of the intervention, without accidental risk of re-energising of the power supply. Clean the machine, as per the procedures specified in this manual.

Machine tests carried out by the manufacturer

The manufacturer, before placing a machine on the market, carries out a series of tests to ensure that the machine functions correctly:

- Functional tests to check the electrical system and grounding.
- Functional tests to check the mixer functions.
- Tests to check the AERIAL NOISE level: less than 70 dB (A).

4 RISKS, PROHIBITIONS, OBLIGATIONS



It is prohibited to put out fires with water



It is prohibited to start up the machine before having checked the safety devices



It is prohibited to clean the machine in the presence of moving members



It is obligatory to disconnect the machine before carrying out any intervention on the machine itself. In particular: disconnect the machine from the electrical supply by ensuring that the electrical panel on the machine and the machine power cable are isolated from the main power supply in a safe manner for the entire duration of the intervention, without accidental risk of re-energising of the power supply.



It is obligatory to ground the machine.

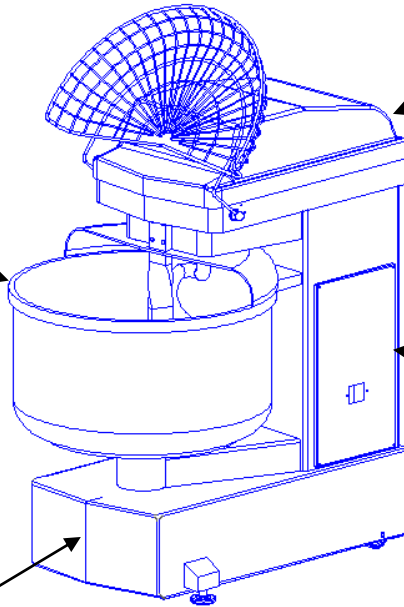

ATTENTION!

- Wear the correct protective clothing during all interventions.
- Carefully clean the machine; the products used in the production process can cause allergies or infections.
- Do not place heavy or dangerous objects on top of the machine.
- Do not place objects or accessories through the opening in the protective bowl cover.
- Do not remove the safety devices and the protective covers.

5 DESCRIPTION OF THE MACHINE AND ITS USE

Intended use of the machine

This line of spiral mixers has been designed for the purpose of kneading food dough, which has as primary ingredients flour and water. A rotating spiral tool, as a result of the powerful mechanical action of the mixer, rapidly and efficiently amalgamates, mixes, refines, kneads and incorporates air into the dough contained in the bowl. Originally conceived for the preparation of bread dough, the mixer has subsequently been found to be also suitable for all leavened dough and bakery products composed of the following ingredients: any type of flour, water, yeast, fats-butter, sugar, legally-approved food essences and food colourings, salt, liqueurs and other ingredients suitable for bread and confectionery products. This line of mixers is not suitable for mixtures with less than 55% humidity. The maximum time interval of continuous use and the corresponding minimum time interval of rest for this mixer vary according to the recipe used (type of dough being kneaded); therefore, the user must refer to the manufacturer with the recipe for this information.

Percentages of ingredients

Based on the percentage of each ingredient, there is a maximum quantity of each ingredient which can be introduced into the bowl in order to respect the maximum dough capacity specified for the mixer.

For additional information on the maximum dough capacity and percentage of flour for a specific mixer, refer to Appendix 2.

Machine structure

The mixer is composed of the following components:

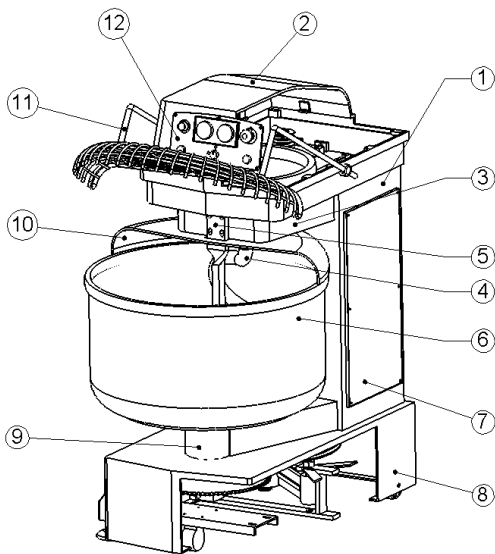

- A robust, steel body (1) (reinforced with metal profiles where the mechanical stress is greater) contains and supports the various machine components.
- The upper transmission group (located under the head cover (2)) rotates the spiral tool (4). This movement is executed by means of a robust, forged shaft carried by a support with ball bearings (3).
- The spiral tool (4), as a result of its shape and movement, mixes and refines the ingredients by pushing them against the breaking column (5) and the sides of the bowl (6).
- The bowl (6), as a result of its rotation, constantly brings dough still to be kneaded under the spiral tool.
- The control panel (12), located on the head cover, contains all the control and program logic. It executes each programmed work cycle and, by means of servomechanisms in the electrical panel (7), drives the various motors in the programmed manner for the

programmed time.

- The lower transmission group (located inside the base (8)) rotates the bowl (6). This movement is executed by means of a robust, forged shaft carried by a support with ball bearings (9).
- The safety covers for the bowl (10), upper transmission group (2) and lower transmission group (not visible because located under the base (8)) serve to protect persons from accidentally coming into contact with the moving members of the machine.
- The mobile safety cover (11), if opened during a work cycle, stops the machine by means of a microswitch.

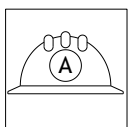

The adjustment of the minimum opening of the mobile safety cover required to activate the microswitch is carried out by the manufacturer, in the manufacturing location, during the machine test phase. Any subsequent modification to the original manufacturer settings can only be carried out by the manufacturer's authorised personnel.

General machine operation

After having correctly installed the machine, it is necessary to select the work cycle required (i.e. the type of operating mode and the corresponding operating times - refer to Appendix 1). Place the water, flour and the other ingredients necessary for the dough into the bowl in the required quantities (not exceeding the maximum quantities allowed – refer to Appendix 2). Lower the mobile bowl cover and start the machine by pressing the Start button. The machine carries out the work cycle in the selected manner for the set time. It is possible to stop the machine at any time by pressing the Stop button and to start it again by pressing the Start button. The detailed description of the control panel and its use is described in detail in Appendix 1.

6 PRESERVATION OF THE MACHINE

Preservation of the machine before a long period of disuse

- Disconnect the machine from the power supply.
- Clean the machine thoroughly.
- Protect the machine from atmospheric agents, dust and dirt.

Storage of the packed machine

The machine must be stored in a hygienically clean, closed, covered environment, positioned on a flat and solid surface and protected from atmospheric agents, dust and dirt.

The temperature of the environment must be between -20 and $+40^{\circ}\text{C}$, while the humidity of the environment must not exceed 90%.

Storage of the unpacked machine

When the machine has already been unpacked, in addition to the above specified conditions, it must also be raised from the ground (fastened to a suitable pallet or other secure platform) and carefully covered to protect it against humidity, dust and dirt. If the machine is wrapped in cellophane or other plastic coverings, then it is absolutely necessary to ensure that it is not hermetically sealed, in order to avoid corrosion due to condensation. If possible, preserve the original packaging.

ATTENTION! It is absolutely forbidden to store the machine outdoors!

7 UNPACKING THE MACHINE

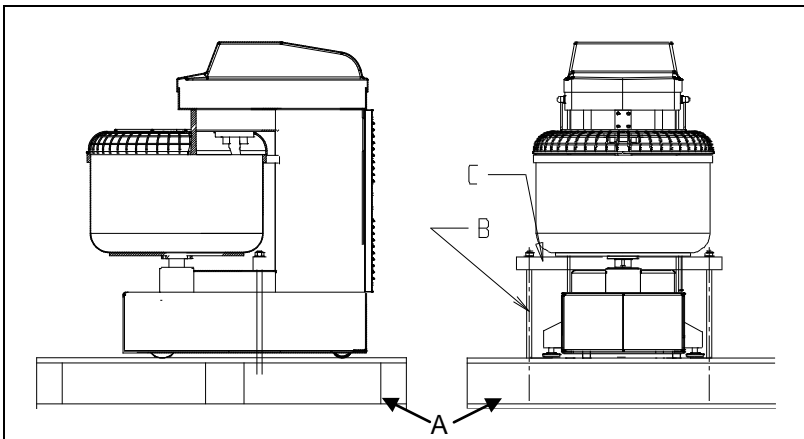

As shown in this figure, the machine rests on a wooden pallet (pos. A) and is held in place by two vertical threaded bars (pos. B) and one transverse bar (pos. C).

The machine always rests on a pallet and can then be packed in one of the following ways:

- machine wrapped in nylon bubble wrap;
- machine placed in a thick cardboard box;
- machine placed in a wooden crate;
- machine placed in a wooden box.

The information concerning the gross weight appears on the outside of the packaging.

In order to unpack the machine, it is first necessary to remove the outer packing material, then the two vertical threaded bars from the pallet and then the transverse bar

All the material used for the packaging, excluding the vertical threaded bars and the transverse bar, can be recycled or disposed of as ordinary urban waste, in accordance with local waste disposal laws.



8 HANDLING THE MACHINE

When lifting and/or moving the machine, it is absolutely necessary to respect the instructions in this section, all the safety instructions and local safety standards and regulations in force.

ATTENTION! Before starting any handling procedure, check the total weight of the machine with and without packaging and then use appropriate, correctly positioned equipment to lift the packed/unpacked machine as per the procedures specified below.

Lifting the packed machine (by means of a fork lift truck or transpallet)

Insert the forks into the pallet in the positions indicated in the following figures.

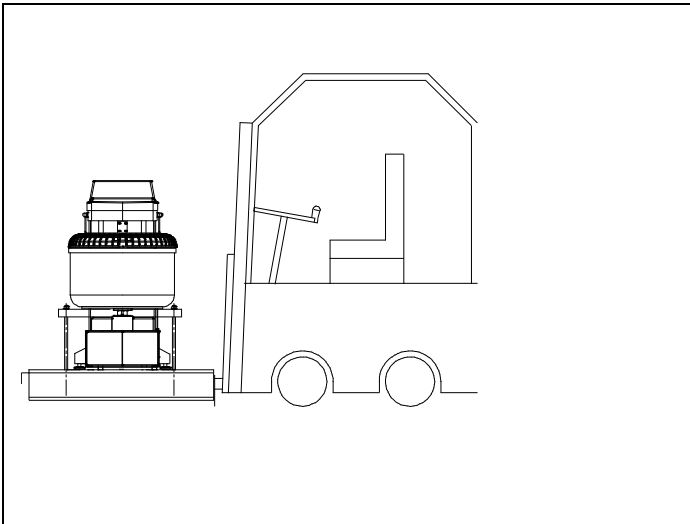

Primary equipment handling regulations:

- Ensure that the lifting device is suitable for the load to be handled.
- Open the lifting forks to the width required to correctly position them without damaging the pallet and/or the machine itself.
- Place the forks in the barycentric position, which does not always correspond to the centre of the packed machine.
- Before lifting the packed machine, ensure that the end of the forks protrude from the pallet.
- While moving the machine, keep it close to the ground.
- Ensure that the area across which the load is moved is clear of objects, persons and animals.
- Wear suitable, protective clothing.

Lifting the unpacked machine (by means of a belt)

The unpacked machine can be lifted using a belt positioned under the machine head, between the column and the spiral mixing tool (as illustrated in the figure below). In order to prevent the machine cover from being damaged, use a spacer (for example, a suitable wooden board with a minimum section of 25x130 mm) to keep the belt away from the cover; this spacer must be securely fastened to the belt to ensure that it cannot move or come out of the belt during the lifting manoeuvres.

ATTENTION! During the lifting procedure, the machine is in an inclined position (3-5° on the heavier side) since the centre of gravity has been shifted. However, this does not compromise the safety of the persons or of the machine itself. Avoid oscillations during this operation.

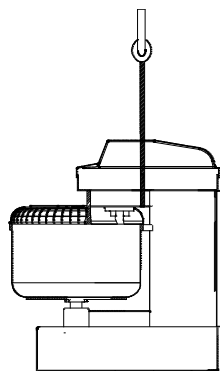
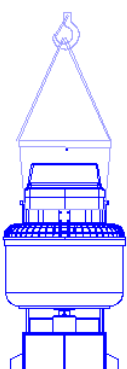

Primary equipment handling regulations:

- Ensure that the lifting device is suitable for the load to be handled.
- While moving the machine, keep it close to the ground.
- Ensure that the area across which the load is moved is clear of objects, persons and animals.
- Wear suitable, protective clothing.

Moving the unpacked machine manually

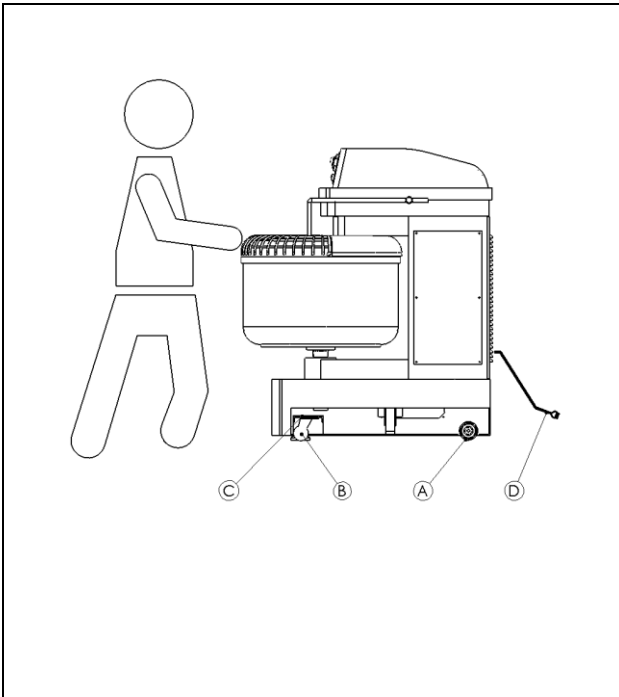

ATTENTION! Before moving the machine in any way, ensure that the machine has been disconnected from the power supply (by turning off the main switch and then disconnecting the machine plug (D) from its socket)

The unpacked machine can be moved manually thanks to the wheels mounted underneath the machine. When moving the machine in this manner, pay attention to the following precautions:

- The machine must be moved slowly and carefully.
- The machine must only be moved across flat, smooth, solid surfaces, without changes in level.

The machine rests on three wheels: two fixed wheels (A) at the back and one revolving wheel (B) at the front. The machine can be moved manually, simply by adjusting the levelling feet (C) so as to lower the front, revolving wheel to the floor and then pushing the machine to the desired position. This manoeuvre is useful to move the machine in order to clean the space underneath it.

9 INSTALLATION OF THE MACHINE AND POSITION OF THE OPERATOR

Operating conditions

Environmental conditions: The machine must be installed on a solid and level surface, inside a well lit and ventilated building.

The temperature of the environment must be between 5 and 40°C and the humidity of the environment must not exceed 90%.

Illumination: The light available for the person operating on the machine must be suitable for the type of task being executed, according to current legislation. The lighting must be sufficient to clearly read the machine controls and warning/danger signs, without blinding the operator.

Vibrations: If the machine is used correctly, then the vibrations present during the operation of the machine do not constitute any type of danger.

Electromagnetic interference: The machine referred to in this manual has been designed to operate correctly in an industrial type of electromagnetic environment.

Cleanliness of the work environment: The machine may only be used in environments suitable for the storage and production of food products. Furthermore, it is necessary to respect the following operating conditions:

- The absence of ventilation while loading the ingredients and during the initial phase of the work cycle (amalgamation of the ingredients), to prevent excessive food powder emissions.
- The use of containers and tools which are suitable for handling food products.

Position of the machine and of the operator

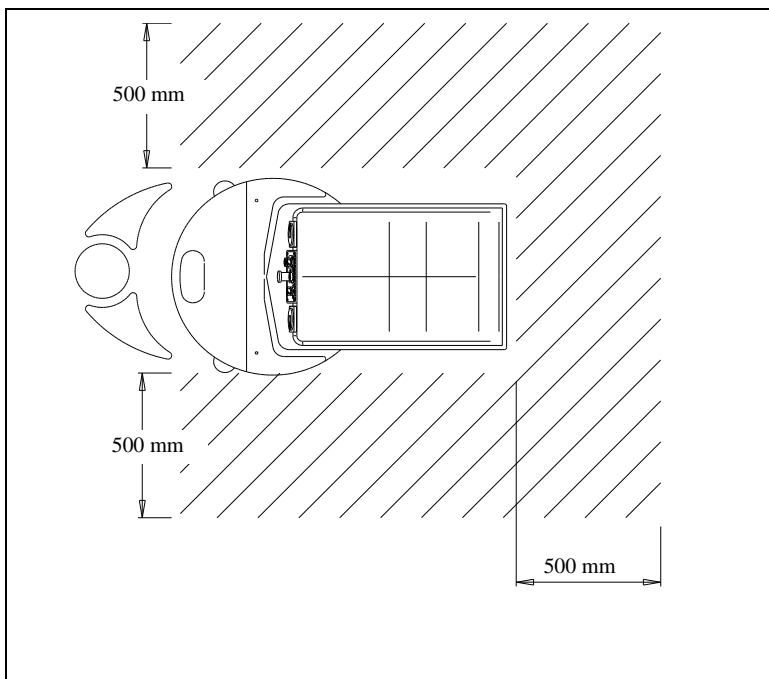

Carefully select the location for the machine in the workplace, ensuring that the floor is level and that there is enough space to allow the operator to easily load the ingredients and remove the kneaded dough. Furthermore, provide sufficient space around the machine for the cleaning and maintenance procedures (as per the figure alongside).

The machine has been designed for use in bakeries or confectioneries and, therefore, in environments with extremely variable temperatures and humidities (as specified in the above section *Environmental conditions*).

Avoid an excessive ventilation of the work environment which could lead to flour emissions from the bowl during the loading and initial phase of the work cycle.

The figure alongside illustrates the correct position of the operator with respect to the machine.

Fixing the machine in place

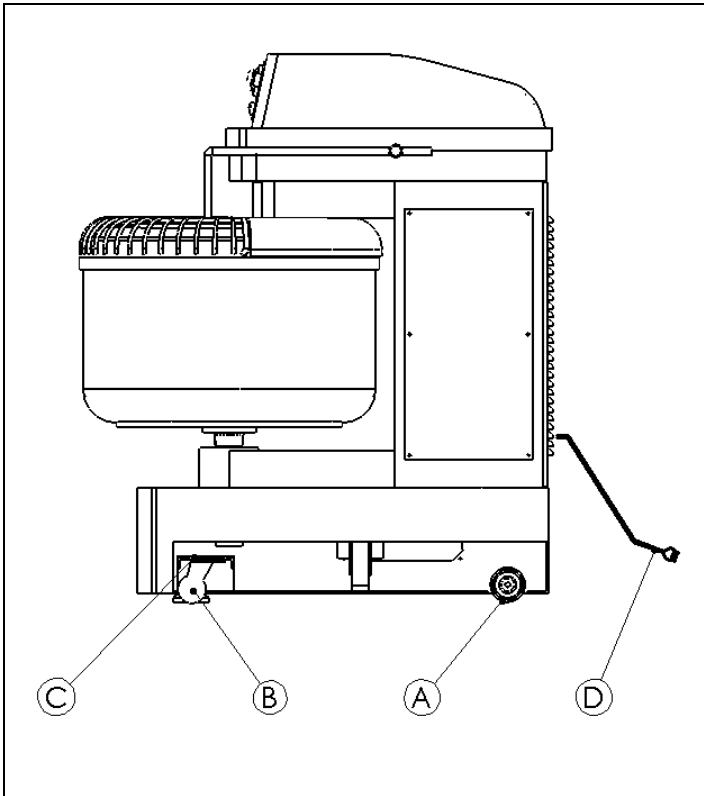

Machine stability

The machine must rest on a horizontal, smooth, solid surface without level changes. Once the machine has been correctly positioned in the selected location, it must be fixed to the ground simply by adjusting the levelling feet (C) until the front, revolving wheel (B) is lifted off the floor and the machine is stable and level. Check that the machine is level by using a simple bricklayer's level.

10 ELECTRICAL SYSTEM



Connection to the power supply

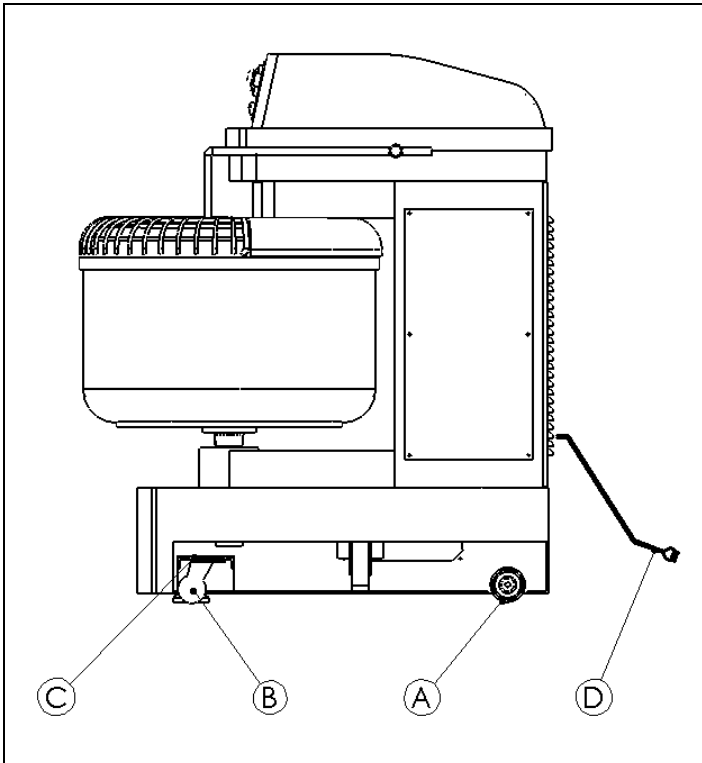

ATTENTION! Ensure that the voltage (V), frequency (Hz) and number of phases of the power supply correspond to those specified on the serial plates of the machine and of the motor; an incorrect connection will damage the machine and will invalidate the guarantee.

Connect the power cable (D) to a socket having all the required characteristics (as specified in the *Machine Specification Sheet* in this manual).

Turn on the main switch.



Disconnecting the machine supplied with plug attachment from the power supply

First turn off the main switch and then the socket switch before removing the plug from its socket.

11 CLEANING THE MACHINE

The machine has been designed for the production of food products and, therefore, it is indispensable that it be thoroughly cleaned and sanitised every day, as per local sanitation requirements for food production environments.

Cleaning the body of the machine

It must only be cleaned using a damp cloth which has been soaked in water and sufficiently wrung out. The cloth must be selected and sanitised as specified by local sanitation requirements for food production environments. It is absolutely forbidden to use cleaning tools which can scratch or damage the machine.

Cleaning the inside of the bowl and the mixing tools

Remove all dough residue using a suitable tool which will not scratch or damage the internal surface of the bowl and the mixing tools. Use water and, if necessary, a food grade soap, to clean the bowl. Rinse the bowl thoroughly. Sanitise the bowl as specified by local sanitation requirements for food production environments.

Cleaning the surface underneath the machine

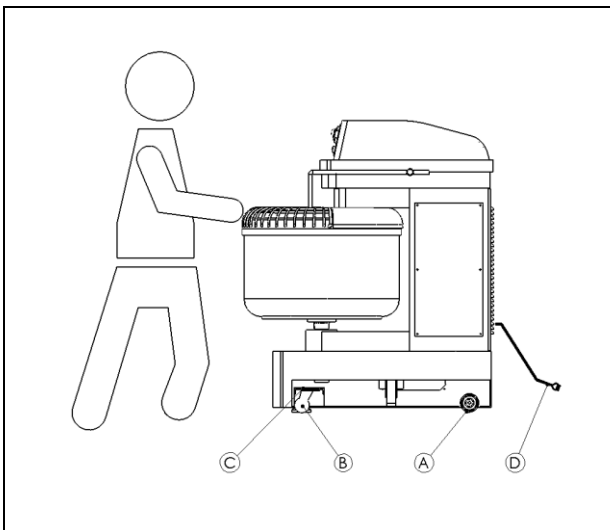

The surface underneath the machine must be kept clean.

The machine is equipped with three wheels (two, fixed rear wheels (A) and one, revolving front wheel (B)) which allow it to be moved manually, permitting the surface underneath the machine to be easily accessed and hence, cleaned.

ATTENTION ! To move the machine manually, proceed as follows:

- Remove the plug (D) from its socket.
- Adjust the levelling feet (C) so as to lower the revolving front wheel (B) to the floor.
- Push the machine to the required position. Move the machine slowly and avoid sudden movements. Only move the machine along flat, smooth and solid surfaces without level changes.



12 OPERATING PROCEDURES

ATTENTION! Strict observance of the safety procedures specified in this manual and of the local safety standards and regulations is indispensable when carrying out any operation on the machine.

Preliminary machine check-up

Before starting the work cycle, check that:

- the machine is in a stable position on a flat, smooth and solid surface;
- the machine has been correctly connected to the power supply;
- the machine parts are clean.

Loading the ingredients to be kneaded

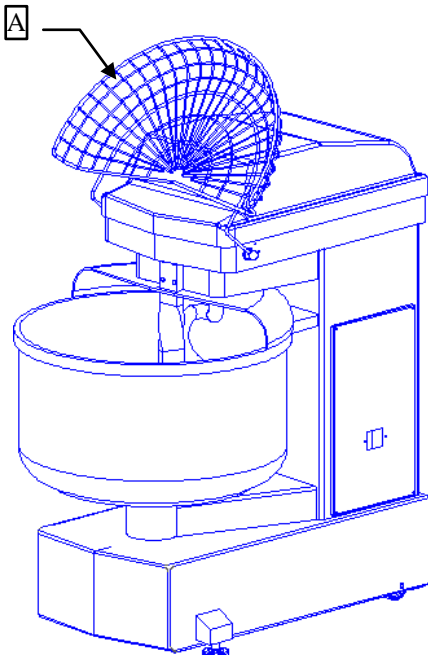

With the machine turned off, it is possible to gain access to the bowl simply by lifting the protective, mobile bowl cover (A).

Check that there are no foreign objects in the bowl and that the bowl is clean.

Load the ingredients (exclusively those suitable and allowed for the production of bread and confectionery products) into the bowl, respecting the maximum quantities allowed for the specific machine (Appendix 2).

The recommended sequence for loading the ingredients is as follows:

1. Pour the required quantity of water into the bowl.
2. Pour the flour into the bowl (in the correct proportion with respect to the water).
3. Subsequently, add the other ingredients for the dough (salt, leavening agent, butter, margarine etc.), by lifting the mobile protective bowl cover and pouring them into the bowl. If the mobile bowl cover is lifted while the machine is operating, then the machine will stop; it is therefore necessary to close the mobile bowl cover and restart the machine to complete the work cycle by pressing the required start button. Small quantities of ingredients can be added to the dough by pouring them directly through the opening/s in the mobile bowl cover, without opening the cover itself.

The operator is strongly advised against loading the flour into the bowl before the water as this creates high density lumps in the dough which cause the machine to function irregularly, thus leading to sudden increases in power which reduce the life of the transmission belts and wear and tear parts in general.

Executing a work cycle

It is only possible to start the machine when the mobile protective bowl cover (A) is closed.

Appendix 1 contains a detailed description of the control panel, its functions and how to program and execute a work cycle.

All the machine commands required to carry out a work cycle are located on the control panel.

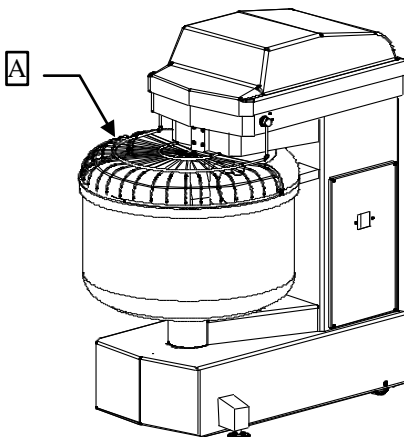

- The Start button starts the set work cycle.
- The time countdown of the work cycle being executed is displayed on the control panel on a digital display or by means of LEDs (depending on the type of control panel).
- If the mobile protective bowl cover is opened, then the work cycle is interrupted; to resume the work cycle, press the Start button again.
- The Stop/Emergency button stops and resets the work cycle; The time display returns to the initial setting of the last work cycle executed.
- The BOWL JOG button (optional) impulsively rotates the bowl without rotating the spiral tool, even when the mobile protective bowl cover is open. It is used to move the dough to the front of the machine to permit it to be easily extracted by the operator.

Warnings relative to repeated interruptions of a work cycle

Once the work cycle has been started by pressing the Start button, the machine continues to knead the dough until the the set work time has elapsed, unless the operator interrupts the work cycle. Avoid repeated interruptions of the work cycle as this leads to the overheating of the motor which, in the long term, can compromise the efficiency of the machine itself.

Stopping the machine

The timers automatically stop the work cycle and hence, the machine, once the programmed time has elapsed. The machine can be stopped at any time by pressing the STOP/EMERGENCY button, however, it is strongly recommended that the operator avoid repeated interruptions. To switch off the machine, turn the main switch to the "O" position.

Unloading the kneaded dough

Upon completion of the work cycle, it is possible to remove the dough from the bowl after having opened the mobile protective bowl cover. The BOWL JOG button (optional) is useful to move the dough to the front of the machine in order to facilitate its extraction. It is strictly prohibited to use any utensil which can scratch or damage the bowl and the mixing tools.

13 PERIODICAL INSPECTIONS, CLEANING AND MAINTENANCE OF THE MACHINE



ATTENTION! Before carrying out any operation related to periodical inspections, cleaning or maintenance procedures, switch off the machine by turning the main switch to the “O” position and disconnect the machine from the power supply ensuring that the electrical panel on the machine and the machine power cable are isolated from the main power supply in a safe manner for the entire duration of the intervention, without accidental risk of re-energising of the power supply.

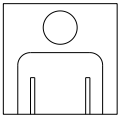

Cleaning procedures and periodical inspections

The first and most efficient form of preventive maintenance is keeping the machine clean; regular and thorough cleaning prevents the buildup of dough residue which, in the long term can damage the moving members.



Before carrying out any inspection or cleaning procedure, the operator must:

- wear protective clothing suitable for the task to be carried out; clothing which must offer protection against organic, chemical, biological, mechanical and/or electrical risks
- switch off the machine and disconnect it from the power supply.

Daily cleaning procedures and inspections:

- Clean the bowl, spiral tool, breaking column and fixed and mobile protective bowl covers, as described in the section *Cleaning the Machine*.
- Visually check that the machine and external safety devices (described in the section *Safety Instructions*) function correctly.



Inspection of the safety devices

The safety devices installed on the machine need to be inspected periodically.

Legend of the frequency of an inspection (FREQUENCY)	Legend of the manner in which an inspection must be carried out (MANNER)
d = daily w = weekly m = monthly a = annually	O = <u>Observation</u> : visual inspection (e.g. check that alarm lights/LEDS function correctly) E = <u>Execution</u> : an action is required to check the response (e.g. when the Emergency button is pressed, the machine must stop) M = <u>Measurement</u> : the inspection requires instrumentation to measure values that need to be checked (e.g. grounding values).

Main switch

Purpose: interruption of the power supply.

Function: This component disconnects the machine from the power supply. Turn it to the various positions and check that it functions correctly in each position. Turn off the main switch and check that there is no current downstream of the component.

Inspection	
Frequency	Manner
a	E

Lights on the control panel

Purpose: display of the machine status.

Different functions on the machine have a corresponding light which comes on when the function is activated. The lights are not necessary for the machine functions, however, they indicate the status of the machine (i.e what task is being executed) and therefore have an important role in the safe use of the machine.

Activate each machine function and check that the corresponding light comes on.

Inspection	
Frequency	Manner
m	O

Stop-Emergency Circuit

Purpose: Disactivation of all the machine functions.

By pressing the red, mushroom-head Stop-Emergency push button the power supply to all the electrical machine components is interrupted and, therefore, all the machine functions are disactivated. The machine function being executed stops in the position it has reached at the time of the interruption, except for those parts subject to inertia (e.g. the spiral tool). To restart the machine, the Stop-Emergency push button must be rotated clockwise until it is unblocked.

Check that the Stop-Emergency push button functions in the above described manner.

Inspection	
Frequency	Manner
m	E

Electrical panel automation

It is necessary to periodically check the machine automation and grounding. The following components must be checked: motor protectors, electrical motors, connectors between control panel and electrical panel, grounding. Switch on the machine and check the behaviour of the described components (first with the machine operating in manual mode and then with the machine operating in automatic mode).

Inspection	
Frequency	Manner
a	E, M

WEEKLY, MONTHLY, ANNUAL Maintenance procedures

WEEKLY MAINTENANCE:

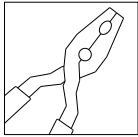

- Clean the machine thoroughly.
- Check that the operating controls and external emergency devices (Stop-Emergency button and protective mobile bowl cover) function correctly.
- Check the external components of the machine: spiral tool, breaking column, bowl.

MONTHLY MAINTENANCE:

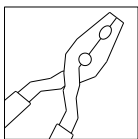

- Lubricate the bearings, if necessary.
- Check the tension of the belts.
- Check the transmissions for irregular noises.
- Check the tightness of the spiral and breaking column bolts (refer to the table of bolt tightening torques below).
- Check the efficiency of the gas struts, for models using these components to control the opening of the mobile bowl cover, and replace them if necessary.

ANNUAL MAINTENANCE:



- Check the electrical system.

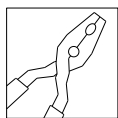

- Clean the machine and check it thoroughly (both externally and that it functions correctly).
- Thoroughly check the transmission members.
 - The transmission belts must be replaced when they start to fray or when under excessive tension, *before* they actually break. It is necessary to replace the entire set of belts relative to a transmission, even if only one of the belts requires replacement.
 - The bearings are subject to wear, especially under the following conditions: poor cleaning procedures, excessive use of the machine in first speed in the reverse direction, poor use of the machine which can lead to food products being deposited inside the group of bearings therefore reducing the life of the bearings themselves. The replacement of the bearings must be carried out by a suitably qualified technician using appropriate equipment and in full observance of the safety measures and local safety regulations.
 - Check the tightness of the bolts on the entire machine.



Indicative Bolt tightening torques

	Nominal Size thread					
	M6	M8	M10	M12	M14	M16
Tightening for Bolts (8.8) [Nm]:	9.7	23	47	80	130	196
Tightening for Bolts (10.9) [Nm]:	13.6	33	64	113	180	275
Tightening for Stainless steel Bolts [Nm]:	6	16	32	56	-	135

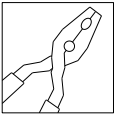

Adjustment of the belt tension and replacement of the transmission belts

The tension of the transmission belts must be adjusted when the rotation of the spiral tool/bowl slows down or is not smooth during the execution of a work cycle.







It is obligatory to:

- wear protective clothing suitable for the task to be carried out,
- switch off the machine and disconnect it from the power supply, before carrying out any operation on the machine.

The procedure for the adjustment of the belt tension and replacement of the transmission belts is described in Appendix 3.

Note: Before replacing the belts, ensure that the new belts have the same characteristics as the original belts installed on the machine by the manufacturer.

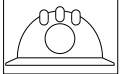
14 TROUBLE SHOOTING

PROBLEM	POSSIBLE CAUSES	SOLUTION
When the main switch is turned to the "I" position, the lights on the control panel do not come on.	<ol style="list-style-type: none"> 1) The machine has been connected incorrectly. 2) The plug has not been inserted correctly into the socket. 3) There is a disconnected wire in the plug. 4) There is a burnt control panel light. 5) The Emergency button has not been released. 	<ol style="list-style-type: none"> 1,2,3) Check the electrical connection.  4) Replace the light bulb.  5) Release the Emergency button, by rotating it clockwise.
When the Start button is pressed, the machine does not start.	<ol style="list-style-type: none"> 1) The mobile bowl cover is open. 2) There is a fault in the safety microswitches. 	<ol style="list-style-type: none"> 1) Close the mobile bowl cover. 2) Replace the microswitches. 
Continuous noise.	<ol style="list-style-type: none"> 1) The bearings are no longer efficient. 	<ol style="list-style-type: none"> 1) Check and, if necessary, replace the bearings. 
The spiral tool stops.	<ol style="list-style-type: none"> 1) The transmission belts are loose. 2) The transmission belts are worn. 	<ol style="list-style-type: none"> 1) Tighten the belts. 2) Replace the belts. 
The bowl stops.	<ol style="list-style-type: none"> 1) The transmission belts are loose. 2) The transmission belts are worn. 	<ol style="list-style-type: none"> 1) Tighten the belts. 2) Replace the belts. 

15 DISASSEMBLING AND DISPOSING OF THE MACHINE

Main components

- Primary materials: Cast iron, steel, stainless steel, bronze, copper, aluminium, rubber, plastic (eg. PET, ABS, PST, polyurethane).
- Surface treatments: Painting (for metallic surfaces); pickling, polishing, satin finishing (for stainless steel parts).
- Forming processes: Rolling and drawing of steel profiles, welding, machining.

Disassembly and disposal of the machine

- The buyer is directly responsible for putting the machine out of service.
- The disassembly of mechanical and electrical components must be assigned to competent persons.
- The machine must be disposed of according to local standards and regulations. In any case:
 - Clean the machine thoroughly.
 - Assign the disposal of the electrical panel to a suitably specialised company.

APPENDIX 1: DESCRIPTION OF THE FUNCTIONS AND OPERATING MODES FOR THE CONTROL PANEL WITH 72x144 SITEC DIGITAL TIMER

ATTENTION!:

The manufacturer reserves the right to modify its machine models as deemed necessary to improve the product. Therefore, when requesting technical assistance and spare parts, always specify:

- The model and type of machine;
- The serial number;
- The year of construction;
- The position, description, part number and quantity of the spare parts required.

For additional information on the machine operation, contact the manufacturer.

All the controls required to operate this machine model are located on the control panel, as shown in the figure below.

The specific function of each button and selector is clearly indicated by graphic symbols located on or next to each control.

The figure shows the control panel for the two-speed model, located on the front of the machine head cover. The first speed (scale 0-10) and second speed (scale 0-20) dials are incorporated into a single timer with a base measuring 72x144 mm.



DESCRIPTION OF PUSH BUTTON CONTROL PANEL

BOWL ROTATION SELECTOR



Selects the direction of rotation of the bowl in the *first speed* operating mode.

In the right-hand position, the bowl rotates in the same direction as the spiral (anticlockwise). In the left-hand position, the bowl rotates in the clockwise direction.

It serves to accelerate the amalgamation of the ingredients.

N.B. The reverse (clockwise) bowl rotation function can only be used for a maximum time of 1 minute; the reason being that, after the dough has reached a certain consistency, it starts beating against the breaking column which can, with time, damage the breaking column itself and, in addition, place the machine under excessive stress.

MANUAL BOWL JOG BUTTON



Impulsively rotates the bowl, without rotating the spiral, even when the mobile bowl cover is open.

The direction of rotation of the bowl is anticlockwise, in the same direction as the spiral.

It serves to bring the dough to the front of the machine to facilitate its extraction from the bowl.

START BUTTON



Starts mixing the ingredients at the speed selected according to the timer settings. (Refer to the section on the mixer operating modes).

In first speed, the bowl rotation direction is selected using the *Bowl rotation selector*. In second speed the bowl rotation direction is always anticlockwise.

TIMER BYPASS SELECTOR



Normal operating conditions:

To permit the machine to function normally, i.e. to activate all the machine functions present on the control panel, it is necessary to turn this selector to the right onto the clock symbol.

Backup operating conditions (to be used only in the presence of a faulty timer):

In the case of a fault in the timer, it is possible to work in a backup mode for a *limited period of time, only until the fault is repaired*. In particular, turning the selector to the left onto the broken clock symbol, it is possible to bypass the timers and use the mixer in 2nd speed in manual mode.



EMERGENCY-STOP BUTTON



The rotation of the bowl and of the spiral tool can be stopped by pressing the Emergency button.

To restart the machine, it is necessary to first remove the emergency condition, by rotating the same push button clockwise until it is released, then press the start button.

The timers are reset.

OPERATING MODES

The mixer can run in three modes, when the mobile bowl cover is closed:

- Manual mode;
- Semi-automatic mode;
- Automatic mode.

These operating modes are selected using the special timer composed of a first speed dial (located to the left) which has a scale of 0-10 minutes and a second speed dial (located to the right) which has a scale of 0-20 minutes. Each timer has three settings:

- ***Count:***
If the timer dial is set above the 0 marking, then the LED corresponding to this setting lights up and flashes when the START button is pressed and the time countdown begins. In this setting the machine works for the time set and in the speed corresponding to the specific dial (first speed for the left dial and second speed for the right dial)
- ***Manual:***
If the timer dial is set below the 0 marking, then the LED corresponding to this setting lights up. In this setting the machine works in manual mode, i.e. in the speed corresponding to the specific dial until the Emergency button is pressed to stop the work cycle.
- ***Excluded:***
If the timer dial is set on the 0 marking, then the LED corresponding to this setting lights up. In this setting the timer is switched off and it is not possible to work in the speed corresponding to this dial.

Manual Mode

To work in manual mode in first speed:



- Set the left (first speed) dial below the zero marking until the “Manual” LED on this timer lights up.
- Press the START button on the control panel to start running in first speed, in order to amalgamate and pre-mix the ingredients.
It is possible to select the reverse bowl rotation direction using the BOWL ROTATION SELECTOR, to accelerate the amalgamation of the ingredients. Before changing the bowl rotation direction, wait 1 second with the selector in the central position, in order to stop the rotation
- Press the EMERGENCY-STOP button to end the manual cycle in first speed.

To work in manual mode in second speed:



- Set the left (first speed) dial on the zero marking until the “Excluded” LED on this dial lights up.
- Set the right (second speed) dial below the zero marking until the “Manual” LED on this timer lights up.
- Press the START button on the control panel to start running in second speed, in order to complete the kneading process.
The bowl rotation direction is anticlockwise, in the same direction of rotation as the spiral.
- Press the EMERGENCY-STOP button to end the manual cycle in second speed.

Semi-automatic Mode

To work in semi-automatic mode in first speed:

- Set the left (first speed) dial to the required mixing time.
- Set the right (second speed) dial on the zero marking until the “Excluded” LED on this dial lights up.
- Press the START button on the control panel to start running in first speed, in order to amalgamate and pre-mix the ingredients. The “Count” LED on the first speed dial lights up and starts to flash. It is possible to select the reverse bowl rotation direction using the BOWL ROTATION SELECTOR, to accelerate the amalgamation of the ingredients. Before changing the bowl rotation direction, wait 1 second with the selector in the central position, in order to stop the rotation.
- The mixer stops automatically when the time set on the first speed dial has elapsed

To work in semi-automatic mode in second speed:



- Set the left (first speed) dial on the zero marking until the “Excluded” LED on this dial lights up.
- Set the right (second speed) dial to the required mixing time.
- Press the START button on the control panel to start running in second speed, in order to complete the mixing process. The “Count” LED on the second speed dial lights up and starts to flash. The bowl rotation direction is anticlockwise, in the same direction of rotation as the spiral.
- The mixer stops automatically when the time set on the second speed dial has elapsed

Automatic Mode



- Set the left (first speed) dial to the required mixing time.
- Set the right (second speed) dial to the required mixing time.
- Press the START button on the control panel to start running in first speed, in order to amalgamate and pre-mix the ingredients. The “Count” LED on the first speed dial lights up and starts to flash. It is possible to select the reverse bowl rotation direction using the BOWL ROTATION SELECTOR, to accelerate the amalgamation of the ingredients. Before changing the bowl rotation direction, wait 1 second with the selector in the central position, in order to stop the rotation. When the time set on the first speed dial has elapsed, the mixer automatically starts running in second speed. At this point the “Count” LED on the second speed dial light up and starts to flash.
- When the time set on the second speed dial has elapsed, then the mixer automatically stops.

General Remarks

- If the mobile protective bowl cover is opened while a work cycle is being carried out, then the machine will stop and the timer will not be reset but will maintain the time reached. To restart the mixer and resume the work cycle, it is necessary to close the mobile bowl cover and press the START button.
- It is only possible to reverse the bowl rotation (using the BOWL ROTATION SELECTOR) in first speed; this function is automatically disabled when the machine is running in second speed. **N.B. The reverse (clockwise) bowl rotation function can only be used for a maximum time of 1 minute; the reason being that, after the dough has reached a certain consistency, it starts beating against the breaking column which can, with time, damage the breaking column itself and, in addition, place the machine under excessive stress.**
- In automatic mode, when the time set for the first speed cycle has elapsed and the bowl rotation direction is reverse (i.e. in the clockwise direction, opposite to the direction of rotation of the spiral), then the bowls stops for approximately 1,5 seconds, before the machine switches to the second speed (where the number of revolutions of the spiral increases and the bowl rotates in the same direction as the spiral). This pause is necessary to allow the bowl rotation direction to be changed and to avoid sudden changes in the direction of rotation of the bowl motor, which in the long term, will damage the motor and hence the machine itself.
- Once the work cycle has been completed, it is possible to move the dough to the front extraction area, by using the JOG BOWL push button, thereby simplifying the extraction of the dough. The JOG BOWL push button, which only rotates the bowl, also functions when the protective mobile bowl cover is open; however, for safety reasons, the bowl only rotates while the button is kept pressed in.

APPENDIX 2: TECHNICAL CHARACTERISTICS: 60-200 MODELS

The table below contains the main technical characteristics of the machine.

TECHNICAL MACHINE DATA	MACHINE MODEL				
	60	80	120	160	200
Maximum Dough capacity (kg)	60	80	120	160	200
Maximum Flour capacity (kg)	36	50	75	100	125
Bowl volume (l)	115	130	186	266	306
Bowl diameter (mm)	670	670	750	850	910
Floor to bowl rim height (mm)	795	835	900	890	890
Length (mm)	1150	1150	1265	1430	1500
Width (mm)	700	700	785	883	944
Height (mm)	1280	1280	1460	1520	1520
Weight (kg)	325	330	488	675	710
Power of spiral tool motor (kW)	2/3.7	2,06/4,8	2,06/4,8	5.9/10.3	5.9/10.3
Power of bowl motor (kW)	0.55	0.55	0,55	0.75	0.75

ATTENTION !

These mixers are only suitable for kneading mixtures with a humidity greater than 55%.

DIMENSIONS AND GROSS WEIGHT OF THE PACKED MACHINE

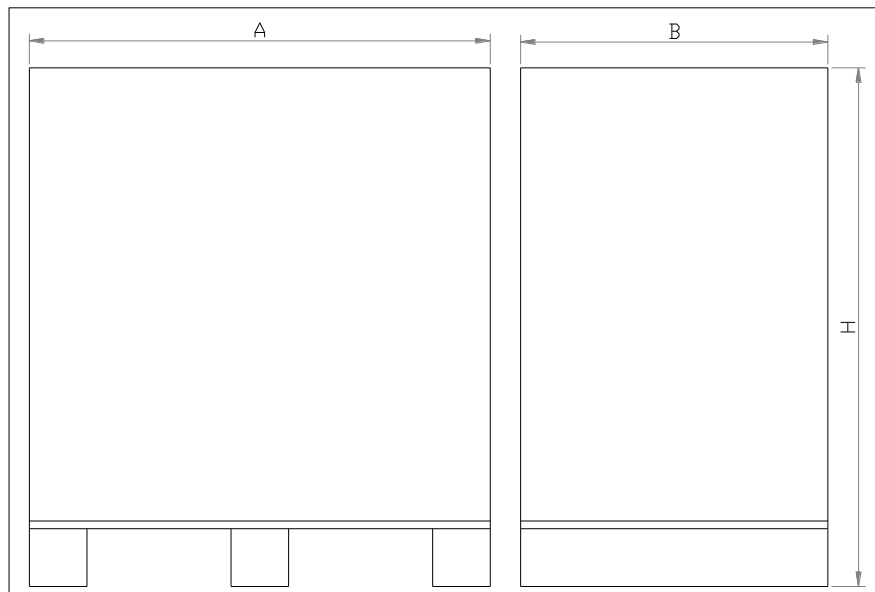

	CARTON ON PALLET		WOODEN CRATE		WOODEN BOX	
MODEL	AxBxH (cm)	Weight (kg)	AxBxH (cm)	Weight (kg)	AxBxH (cm)	Weight (kg)
60	128x81x146 (h)	359	138x88x152 (h)	446	138x88x152 (h)	530
80	128x81x146 (h)	362	138x88x152 (h)	469	138x88x152 (h)	563
120	138x88x168 (h)	548	140x90x177 (h)	626	140x90x177 (h)	720
160	162x107x176 (h)	765	165x110x187 (h)	821	165x110x187 (h)	1.005
200	162x107x176 (h)	821	165x110x187 (h)	877	165x110x187 (h)	1.061

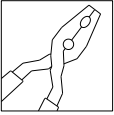

APPENDIX 3: ADJUSTMENT OF THE TENSION AND REPLACEMENT OF THE SPIRAL TOOL TRANSMISSION BELTS

Any type of intervention on the machine must be carried out by suitably qualified personnel, using suitable equipment and in accordance with the local safety standards and regulations in force!

Before carrying out any operation on the machine, it is obligatory to:

- wear protective clothing suitable for the task to be carried out,
- switch off the machine (by turning off the main switch) and disconnect the machine from the power supply, ensuring that the electrical panel on the machine and the machine power cable are isolated from the main power supply in a safe manner for the entire duration of the intervention, without accidental risk of re-energising of the power supply.

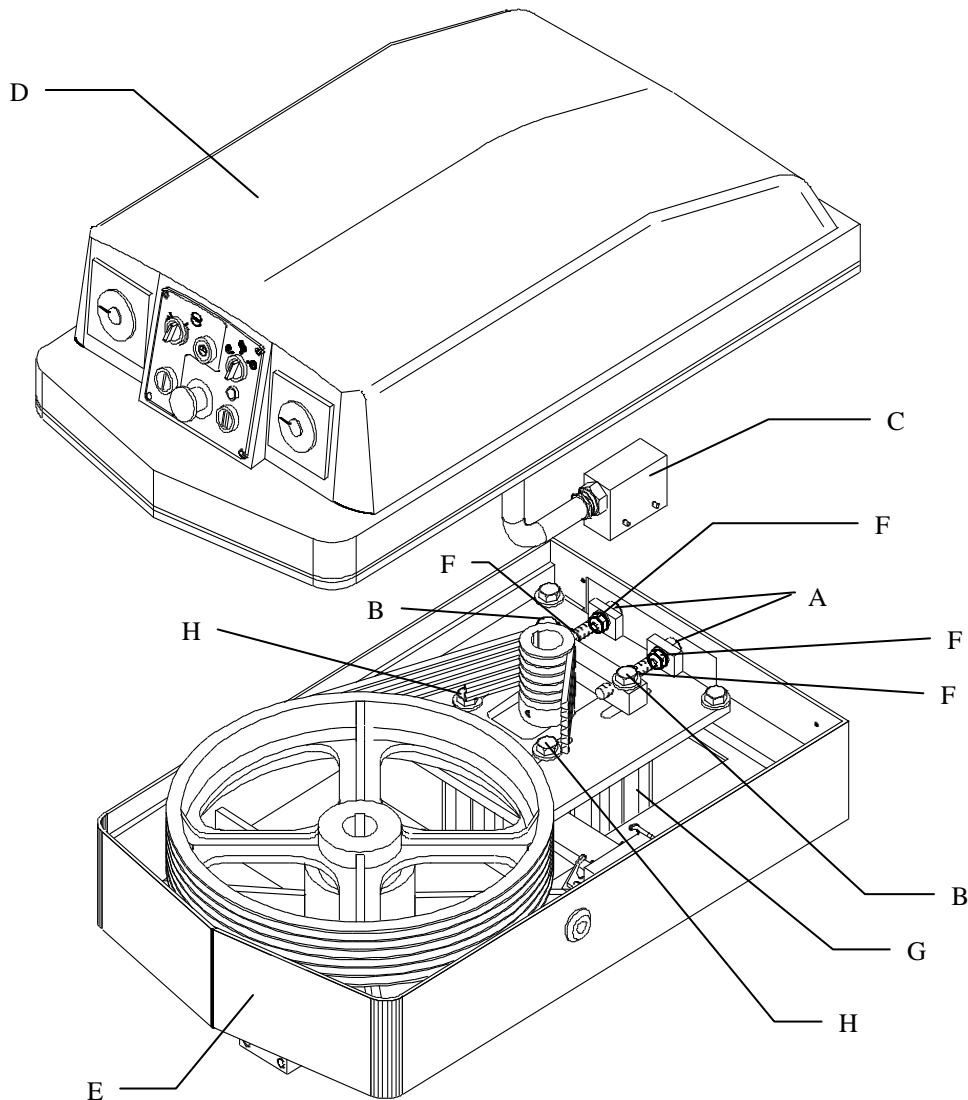

Figure A

(Refer to Figure A)

The belt tension must be adjusted when it is noticed that the rotation of the spiral tool tends to slow down or is not smooth during the execution of a work cycle.

1. Lift the head casing (pos. D) by loosening the screws located on the head cover, which hold it in place.
2. Disconnect the connector (pos. C) from the head cover.
3. Loosen the nuts in pos. F.
4. Loosen the nuts in pos. B and pos. H just enough to permit the spiral tool motor (pos. G) to move backwards and forwards without falling.
5. If it is necessary to replace the belts, then move the spiral tool motor (pos. G) as close as possible to the spiral tool belt pulley to allow them to be replaced.
6. To tension the belts, proceed in the following manner:
 - With the nuts B and H in the position described in point 4, tighten both the nuts in pos. A so as to move the motor (pos. G) away from the spiral tool belt pulley, parallel to the head (pos. E), until the required tension has been reached.
7. Tighten the nuts B and H of the spiral tool motor securely and test the belt tension once again, as this may change slightly once these nuts have been tightened. If the tension is as required, then tighten the nuts in pos. F, bringing them up against the corresponding plates.
8. Reconnect the connector (pos. C), paying attention to the numbering present on the two connectors (socket and plug).
9. Place the head cover (pos. D) back in the correct position, so that it closes onto the head (pos. E), by fastening the corresponding head cover screws accordingly.

Note: When replacing the belts, it is first necessary to ensure that the new belts have the same characteristics as those installed by the manufacturer of the machine.

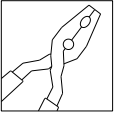

ADJUSTMENT OF THE TENSION AND REPLACEMENT OF THE BOWL TRANSMISSION CHAIN AND BELTS

The chain and belt tension must be adjusted when it is noticed that the rotation of the bowl tends to slow down or is not smooth during the execution of a work cycle.



Any type of intervention on the machine must be carried out by suitably qualified personnel, using suitable equipment and in accordance with the local safety standards and regulations in force!

Before carrying out any operation on the machine, it is obligatory to:

- wear protective clothing suitable for the task to be carried out,
- switch off the machine (by turning off the main switch) and disconnect the machine from the power supply, ensuring that the electrical panel on the machine and the machine power cable are isolated from the main power supply in a safe manner for the entire duration of the intervention, without accidental risk of re-energising of the power supply.

In order to gain access to the base transmission chain and belts, it is necessary to lay the machine carefully on its back, respecting all the safety measures prescribed in this manual and by local law. Figure B shows the view of the base of the machine in this position.

Note: When replacing the chain/belts, it is first necessary to ensure that the new chain/belts have the same characteristics as those installed by the manufacturer of the machine.

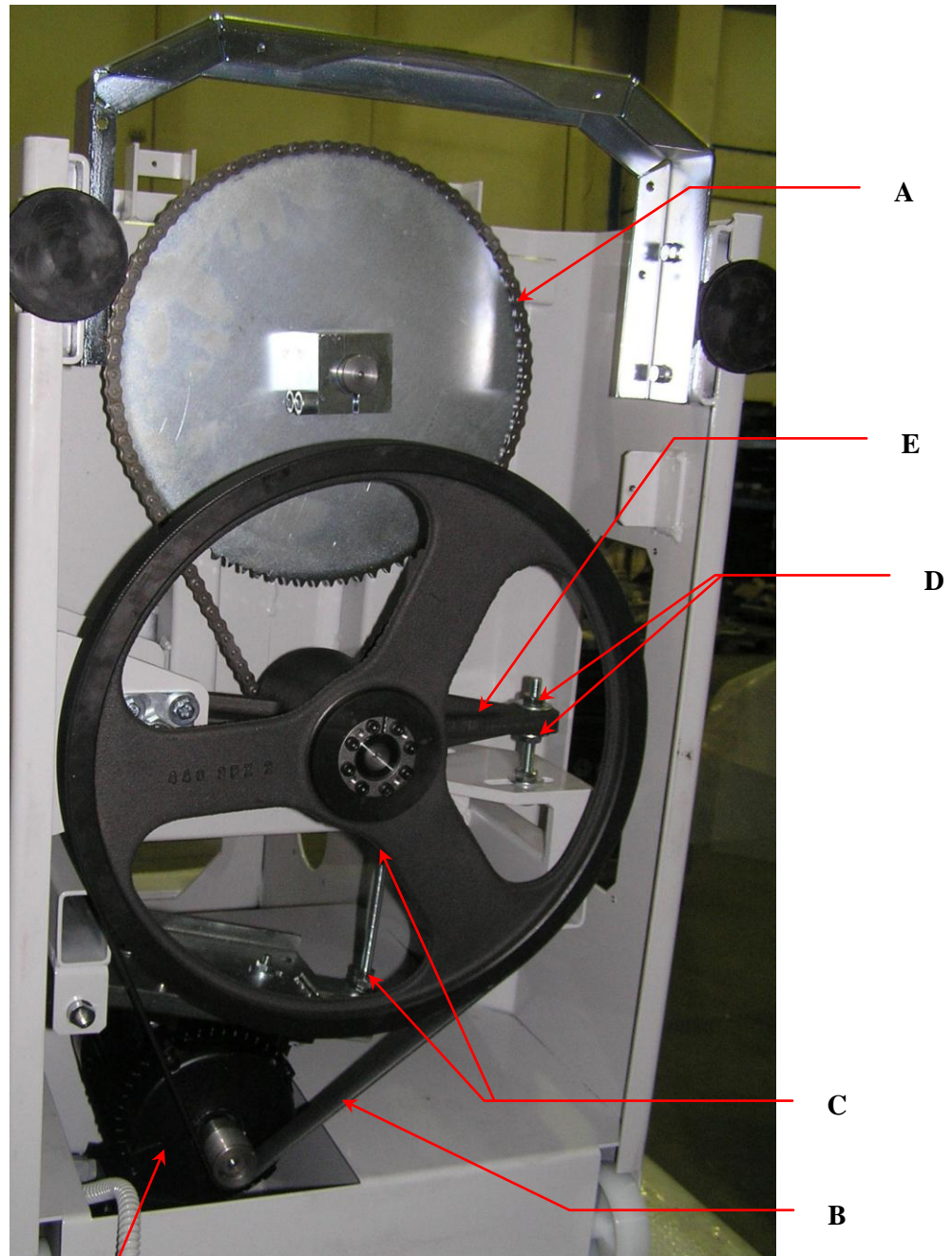

Bowl motor

Figure B

PROC.A Replacement and adjustment of the belt B

1. Loosen the four nuts C.
2. Lift the bowl motor in order to loosen the belt B.
3. It is now possible to remove the belt and to replace it with the new one which has the same characteristics as the original one.
4. Adjust the tension of the belt B using the four nuts C (loosen/tighten the nuts to reduce/increase the belt tension).

PROC.B Replacement of the chain A

In order to replace the chain A, it is first necessary to remove the belt B as described in the above procedure PROC.A.

1. Loosen the upper nut in position D.
2. Lift the transmission support E enough to be able to remove the chain A.
3. Replace the chain with the new one which has the same characteristics as the original one
4. Once the chain has been correctly positioned, it is necessary to carry out the previous instructions inversely.

PROC.C Adjusting the tension of the belt B

1. In order to adjust the tension of the belt B, it is necessary to use the four nuts C (loosen/tighten the nuts to reduce/increase the belt tension).

PROC.D Adjusting the tension of the chain A

1. In order to adjust the tension of the chain A, it is necessary to adjust the upper and lower nut in position D as required

APPENDIX 4

WIRING DIAGRAMS: 60/80 MAG 2V MODEL
with digital SITEC 72x144 timer

POWER WIRING DIAGRAM - (316032)

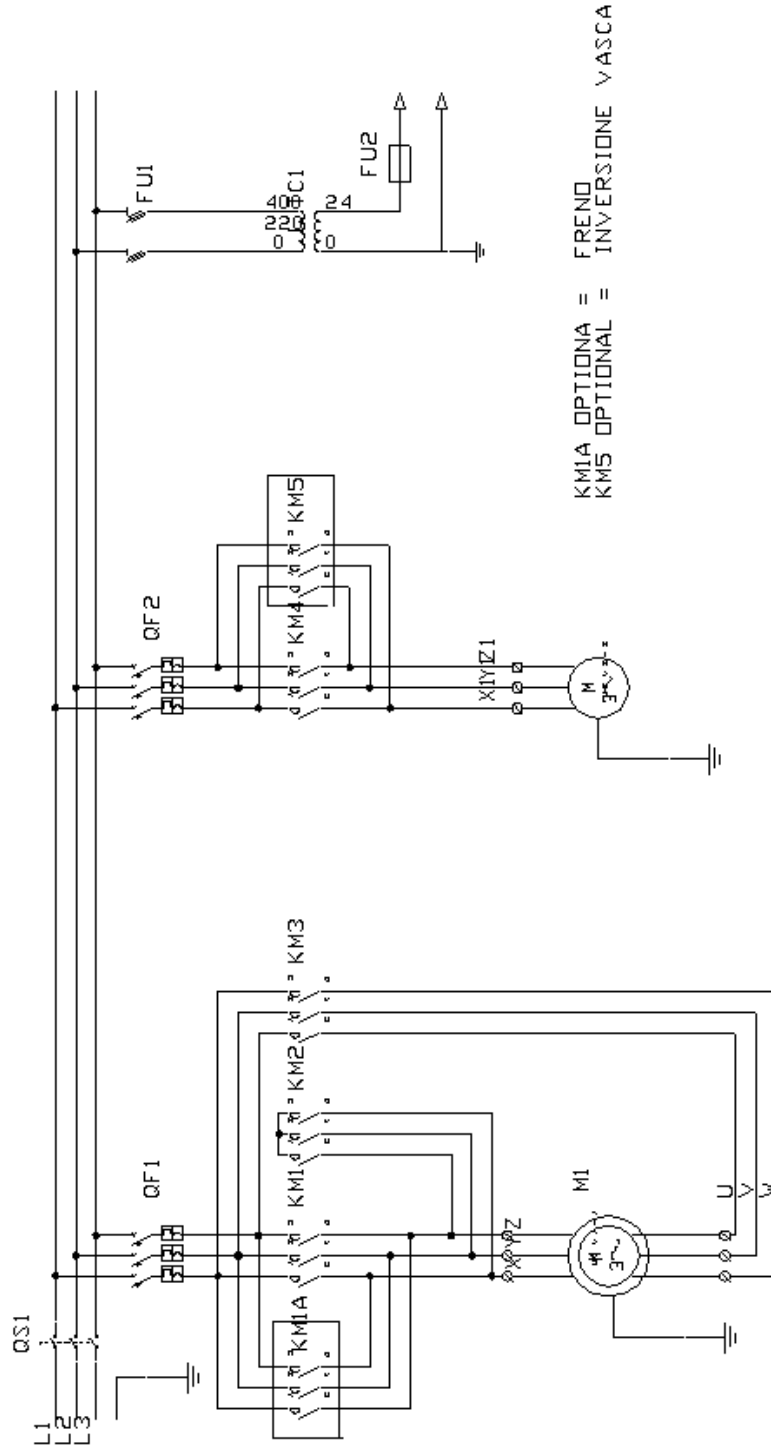

KM1A OPTIONA = FRENO
 KMS OPTIONAL = INVERSIONE VASCA

CONTROL WIRING DIAGRAM - (317118)

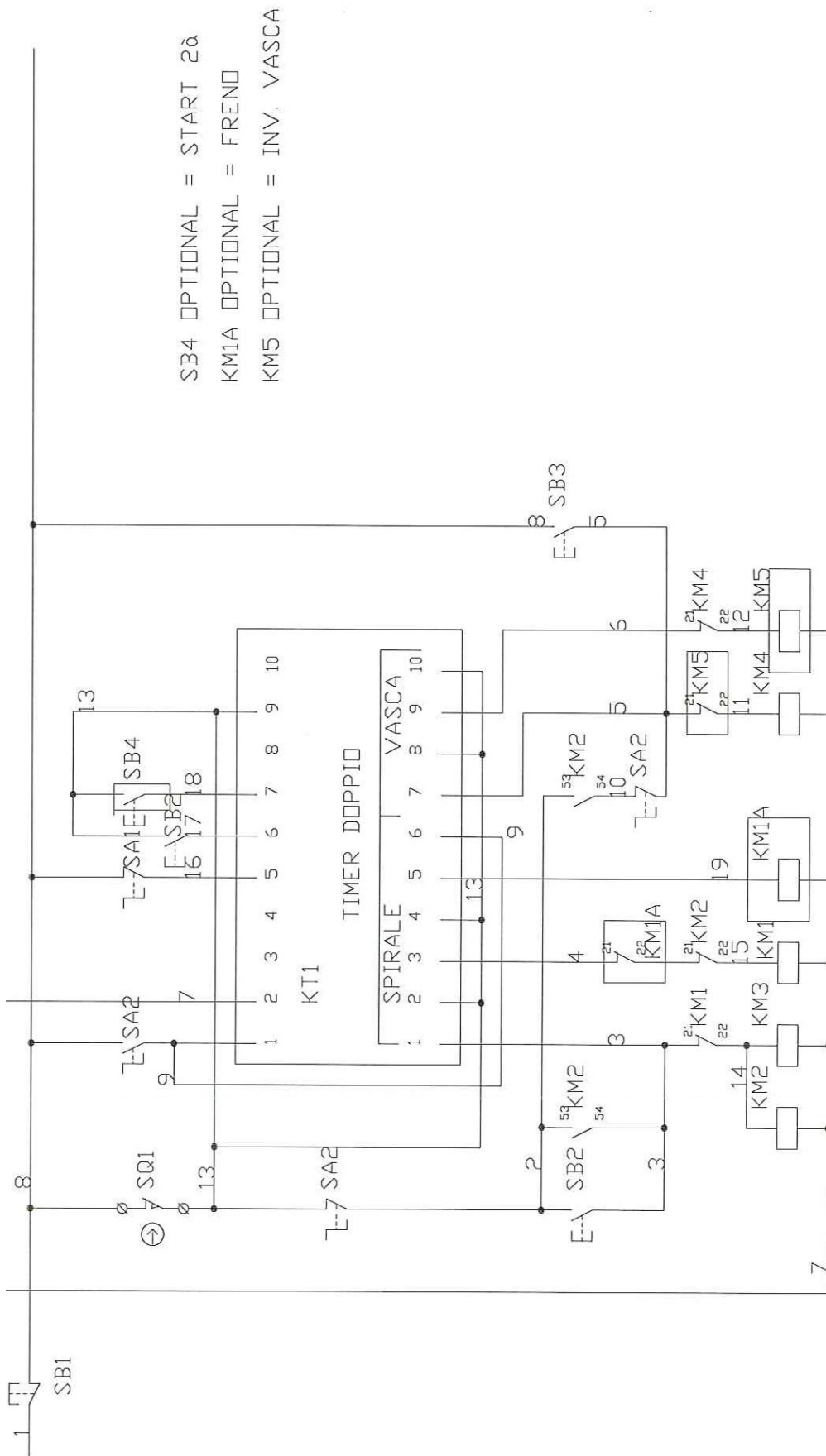

SB4 OPTIONAL = START 2à
 KM1A OPTIONAL = FRENDO
 KM5 OPTIONAL = INV. VASCA

**LIST OF ELECTRICAL COMPONENTS FOR 60-80 MAG 2V MODEL with digital SITEC 72X144 timer
400/415 V 50 Hz SYSTEM (334011)**

ID	Description	Qty	Code
BUILT-IN PANEL			
M1	Spiral tool motor	1	
M2	Bowl motor	1	
QS1	Main switch ILME ZQE 323 + ZR 3280 or SONTHEIMER NLT 16/3E/Z33	1	
TC1	Transformer 150 VA 0.230..400 12-0-12 or 160 VA 0.230.400.415 12.0.12 or 160 VA 0.230.400.415.440 0.24	1	
KM1A*	Contacteur TELEMEC. LC1 K1201B7	1	
KM1	Contacteur TELEMEC. LC1 K1201B7	1	
KM2	Contacteur TELEMEC. LC1 K0901B7	1	
	TELEMEC. LA1KN20	1	
KM3	Contacteur TELEMEC. LC1 K1201B7	1	
KM4	Contacteur TELEMEC. LC1 K0901B7	1	
KM5	Contacteur TELEMEC. LC1 K0901B7	1	
QF1	Magneto thermal TELEMEC. GV2 ME16	1	
QF2	Magneto thermal TELEMEC. GV2 ME07	1	
FU1	Fuse 2A GL	2	
FU2	Fuse 10A GL	1	
	Fuse holder WEBER PCH1 or LEGRAND 10x38	3	
SQ1	Limit switch TELEMEC. XCKN2103G11 or XCKN2103P20	1	
J1	24-pole connector ILME CHI24+CNF24	1	
CONTROL PANEL			
J1	24-pole connector ILME CHO24+CNM24	1	
KT1	Timer SITEC 72X144	1	
SB1	Emergency/Stop push button TELEMECANIQUE ZB5-AS844 + ZB5-AZ102	1	
SB2	Start push button TELEMECANIQUE ZB5-AA1 + ZB5-AZ103 + ZBPO	1	
SB3	Bowl jog push button TELEMECANIQUE ZB5 AA345 + ZB5-AZ101 + ZBPO	1	
SA1	2-position selector TELEMECANIQUE ZB5-AG4 + ZB5-AZ101 + 2*ZBE-102	1	
SA2	2-position selector TELEMECANIQUE ZB5-AD2 + ZB5-AZ102	1	

* Optional

N.B.

- (i) The technical data is not binding. The data can be changed in order to improve the product.
- (ii) Drawings and illustrations are only indicative.

APPENDIX 5: EXPLODED VIEWS OF 80 MAG MIXER AND PARTS LIST

EXPLODED VIEW OF SPIRAL TOOL ASSEMBLY

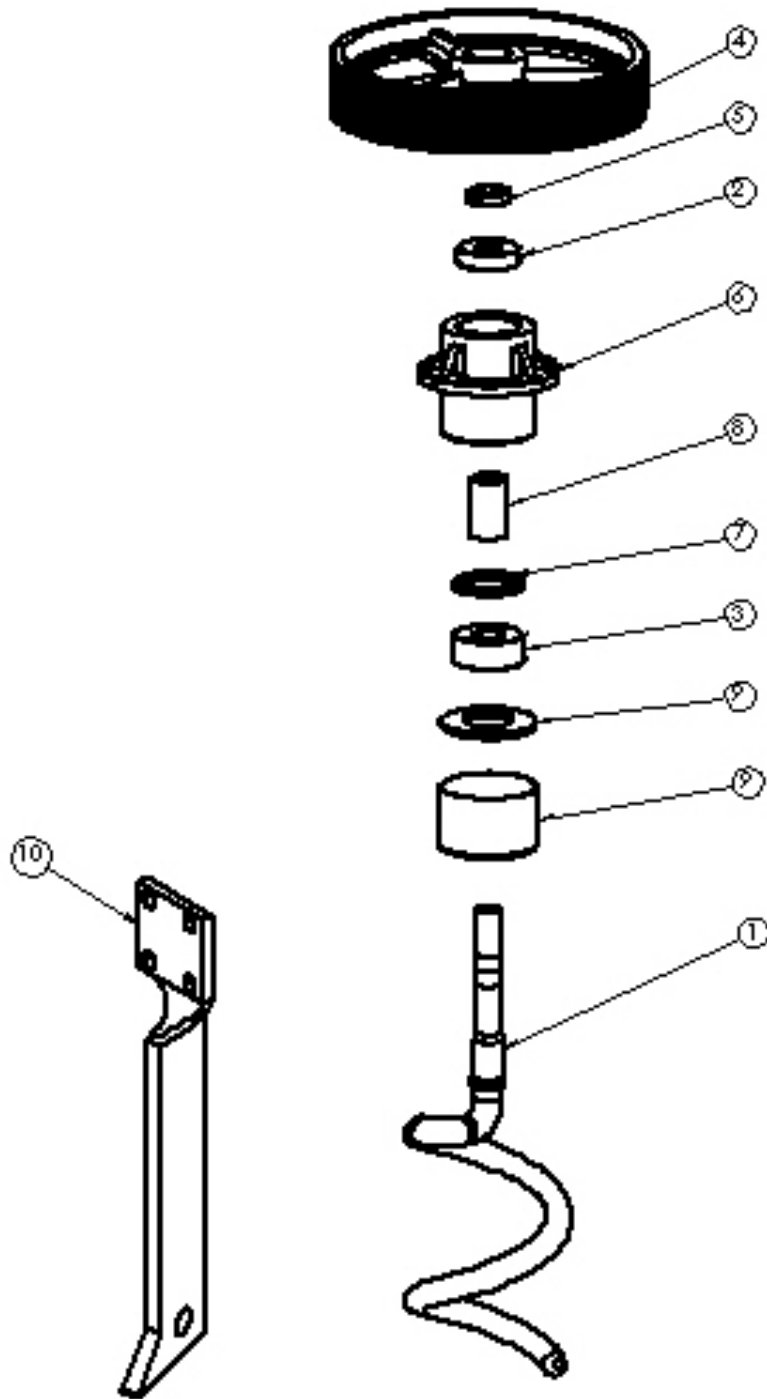

Pos.	Description	Qty	Part no.
1	SPIRAL TOOL	1	220016
2	BEARING 6307 2RS	1	C01066
3	BEARING 3308	1	C01122
4	PULLEY G05 SPZ – FOR 50HZ	1	180039
	PULLEY G 32 POLY-V TYPE J – FOR 60HZ	1	180042
5	LOCK NUT M35X1,5	1	107000
6	SPIRAL TOOL SUPPORT	1	213020
7	SEALING RING MIM 60/090X8	1	C01000
8	SPACER	1	143056
9	CUP	1	135011
10	BREAKING COLUMN	1	177031
ADD.1	BELTS FOR SPIRAL TRANSMISSION XPZ 1512 – FOR 50HZ	5	C00150
	BELTS FOR SPIRAL TRANSMISSION POLY-V 1549 - J32 – FOR 60HZ	1	C00944

ADD: Additional components

EXPLODED VIEW OF THE SPIRAL TOOL MOTOR ASSEMBLY

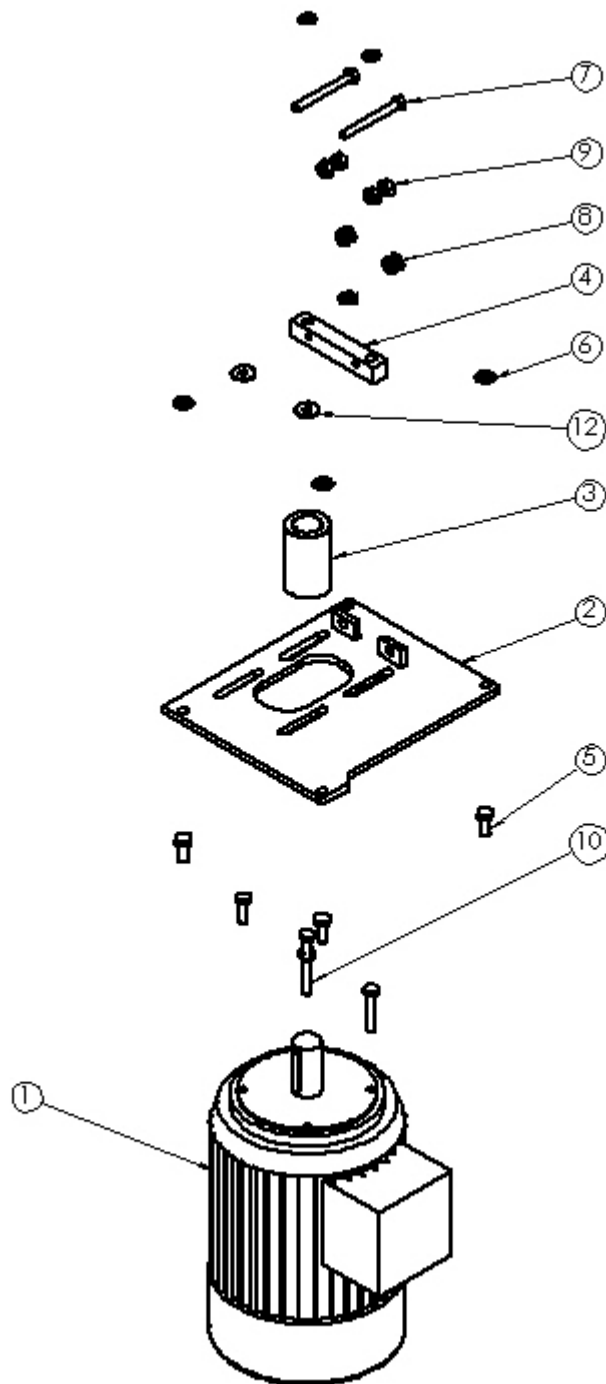

Pos.	Description	Qty	Part no.
1	SPIRAL TOOL MOTOR	1	*
2	MOTOR PLATE	1	191100
3	PULLEY G 05 SPZ – 50HZ	1	183025
	PULLEY POLY-V TYPE J G 32 – 60HZ	1	183063
4	TENSIONING BLOCK	1	113000
5	SCREW M12X35	4	C00010
6	WASHER M12	4	C00075
7	SCREW M10X100	2	C00393
8	WASHER M10	6	C00074
9	NUT M10	4	C00247
10	SCREW M10X60	2	C00392
11	SCREW M10X35	2	C00007
12	WASHER 10/35 X 5	2	C01779

* Refer to electric materials legend

EXPLODED VIEW OF THE BOWL ASSEMBLY

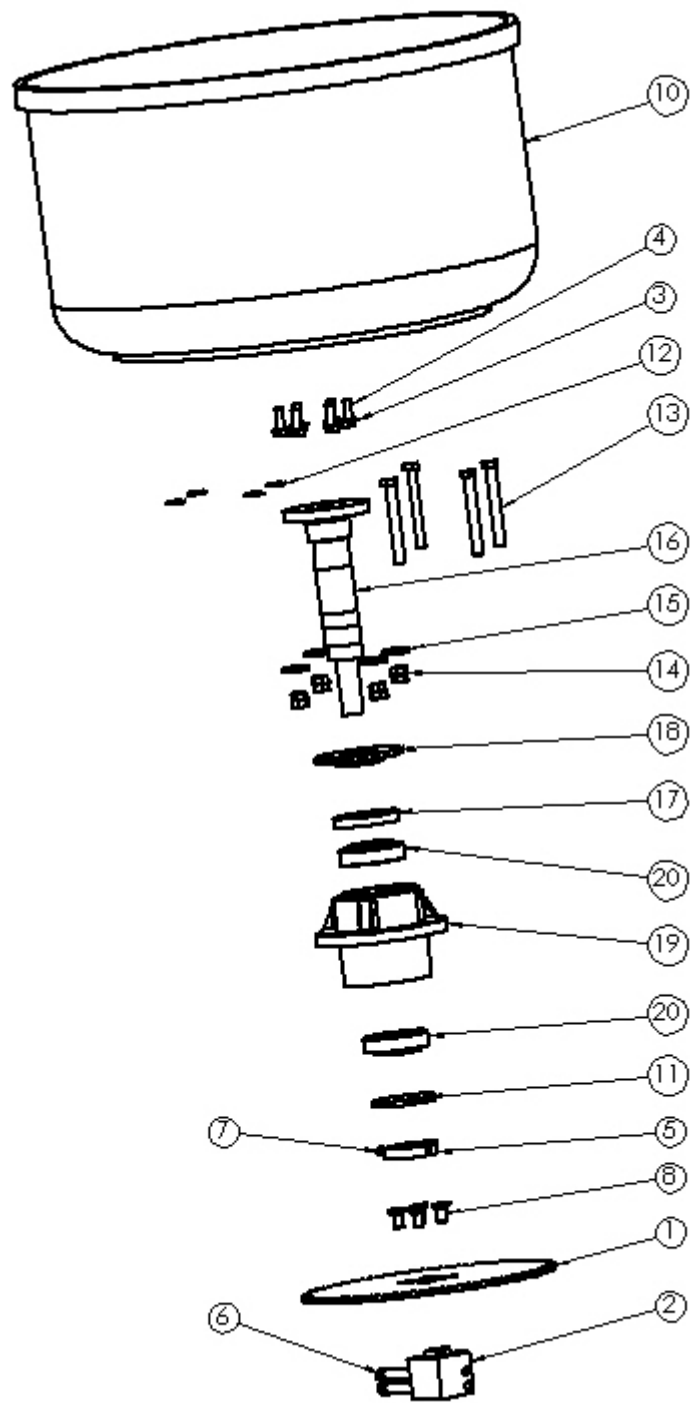

Pos.	Descrizione	Qta	Codice
1	BOWL SPROCKET WHEEL P1/2"x 5/16" Z 85	1	157005
2	HUB FOR BOWL SPROCKET WHEEL	1	163016
3	WASHER M10	6	C00074
4	SCREW M10X25	6	C00000
5	LOCK NUT M50X1,5	1	107001
6	SCREW M12X60	2	C00375
7	SCREW M6X25	1	C00023
8	SCREW M12X25	4	C00571
9	BOWL	1	261072
11	SEALING RING NILOS 32210 TYPE AV	1	C00950
12	WASHER M12	4	C00075
13	SCREW M10X110	4	C01076
14	NUT M12	8	C00049
15	WASHER 14/ 35x 5	4	211011
16	BOWL SHAFT	1	100052
17	SEALING RING MIM 60/090x10	1	C00092
18	BOWL PROTECTION DISC	1	142010
19	BOWL SHAFT SUPPORT	1	213019
20	BEARING 32210	2	C01691
ADD.1	CHAIN FOR BOWL TRANSMISSION	1	C00941

EXPLODED VIEW OF THE BOWL MOTOR ASSEMBLY

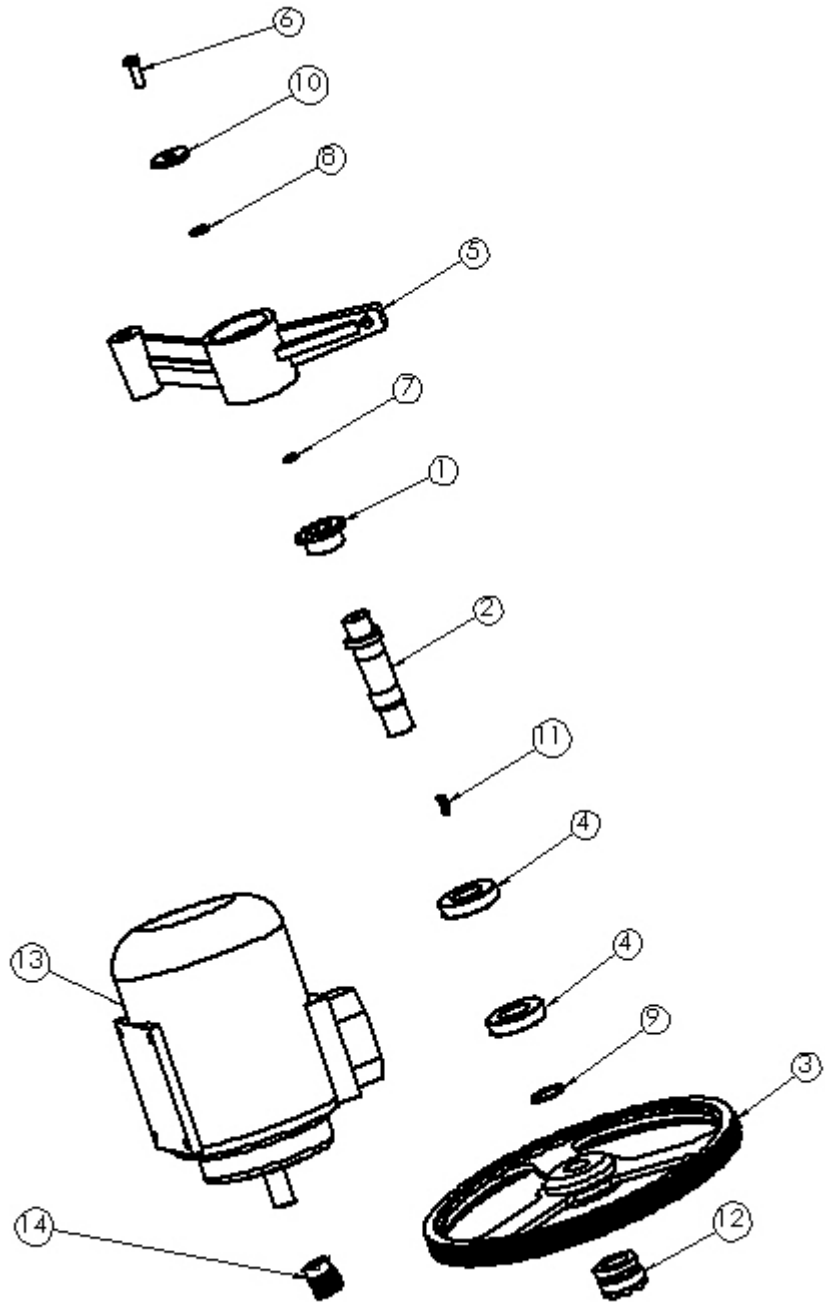

Pos.	Description	Qty	Part no.
1	SPROCKET WHEEL P1/2"x 5/16" Z 16	1	157007
2	BOWL TRANSMISSION SHAFT	1	100089
3	PULLEY G 11 POLY-V TYPE J	1	180043
4	BEARING 6208 2RS	2	C00902
5	BOWL TRANSMISSION SUPPORT	1	213001
6	SCREW M12X35	1	C00010
7	WASHER M12	1	C00086
8	WASHER M12	1	C00075
9	SEEGER RING E40	1	C00058
10	WASHER 13/ 45x 8	1	211038
11	KEY	1	C01628
12	TAPER KEY	1	C01077
13	BOWL MOTOR	1	*
14	PULLEY POLY-V TYPE J G 11-50HZ	1	183065
	PULLEY POLY-V TYPE J G 11-60HZ	1	183064
ADD.1	BELTS FOR BASE TRANSMISSION POLY-V 1549 – J11 (FOR 50 AND 60HZ)	1	C01629
ADD.2	BOWL MOTOR SLIDING PLATE	1	231000

* Refer to electric materials legend

EXPLODED VIEW OF THE BOWL THRUST ROLLER ASSEMBLY

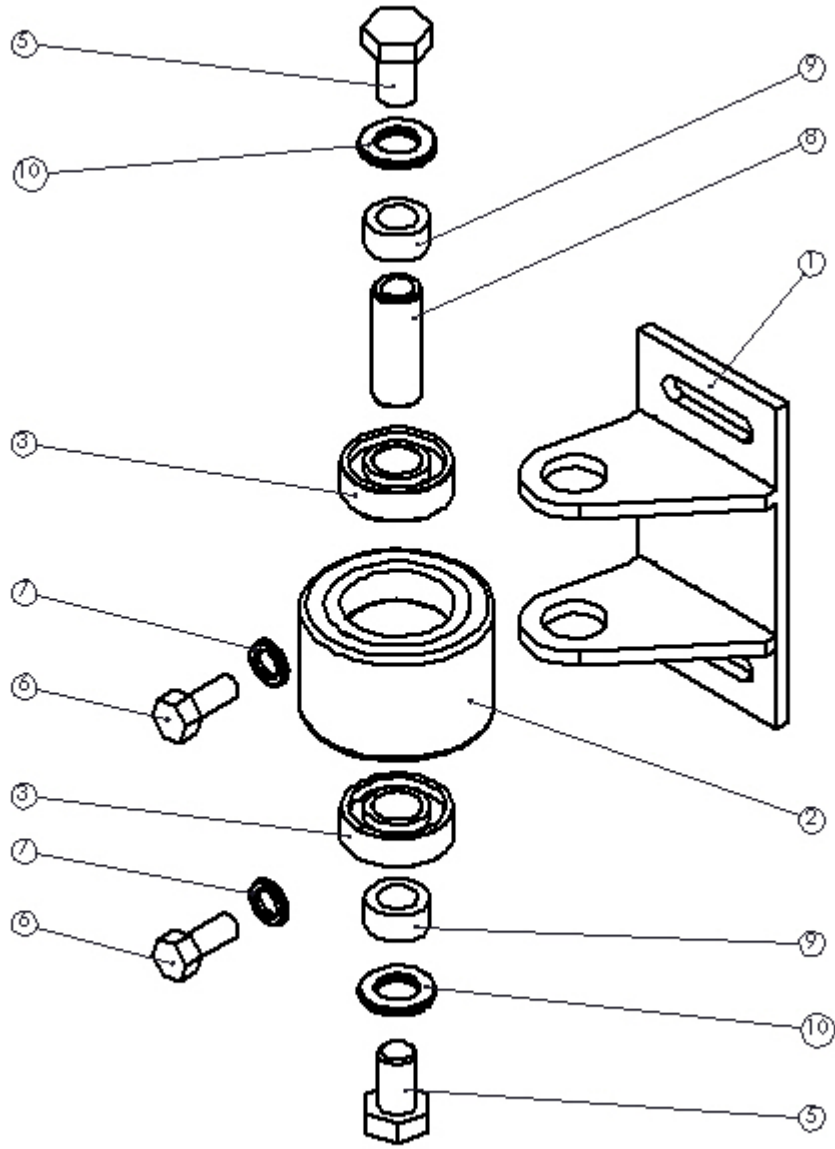

Pos.	Description	Qty	Part no.
1	THRUST ROLLER SUPPORT	2	216091
2	THRUST ROLLER	2	200000
3	BEARING 6202 2RS	4	C00935
5	SCREW M12X30	4	C00009
6	SCREW M8X20	2	C01148
7	WASHER 8/24x2	2	C00376
8	PIN FOR THRUST ROLLER	2	186069
9	SPACER	4	143047
10	WASHER M12	4	C00075

EXPLODED VIEW OF THE MACHINE STRUCTURE

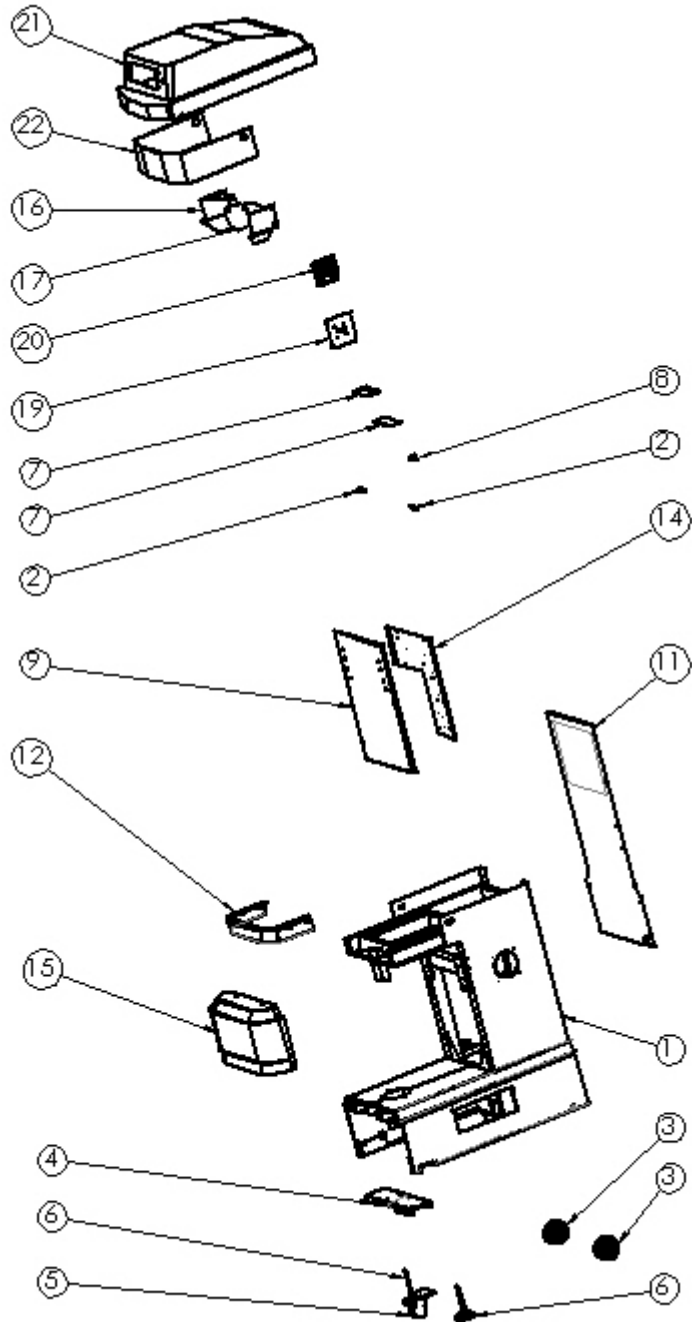

Pos.	Descrizione	Qta	Codice
1	BODY	1	285102
2	SCREW M12X80	2	C01504
3	WHEEL	2	C00254
4	REVOLVING WHEEL SUPPORT PLATE	1	159180
5	REVOLVING WHEEL	1	C00968
6	FOOT	2	C00920
7	CABLE HOLDER PLATE	2	191102
8	CABLE GLAND	1	*
9	FRONT COLUMN COVER	1	208196
11	REAR COVER WITH VENTILATION SLITS	1	159251
12	COVER REINFORCING PLATE	1	159179
14	BASE PLATE FOR ELECTRICAL COMP.	1	159250
15	LOWER FRONT COVER	1	235017
16	LEFT THRUST ROLLER UNIT COVER	1	108009
17	RIGHT THRUST ROLLER UNIT COVER	1	108008
19	BASE PLATE FOR MAIN SWITCH	1	191083
20	MAIN SWITCH	1	*
21	HEAD COVER FOR ELECTRONIC CONTROL PANEL	1	125054
	HEAD COVER FOR DIGITAL 72X144 TIMER	1	125081
	HEAD COVER FOR DIGITAL 72X72 TIMERS	1	125085
22	UPPER FRONT COVER	1	208202
ADD.1	ADHESIVE COVER FOR ELECTRONIC CONTROL PANEL	1	239054
	CONTROL PANEL SUPPORT PLATE FOR DIGITAL SITEC 72X144 TIMER	1	239067
	CONTROL PANEL SUPPORT PLATE FOR DIGITAL SITEC 72X72 TIMERS	1	239060

* Refer to electric materials legend

EXPLODED VIEW OF THE BOWL COVER

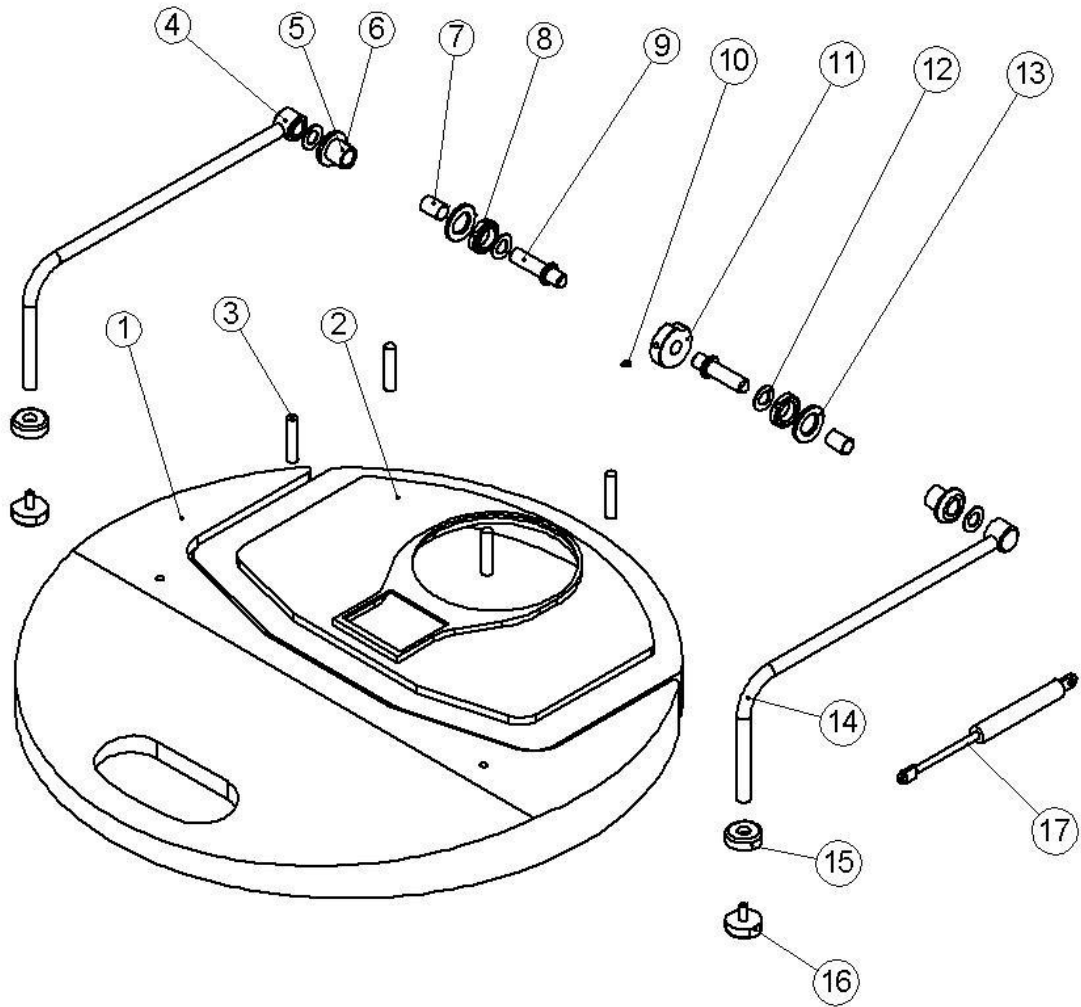

Pos.	Descrizione	Q.	Codice
1	MOBILE BOWL COVER IN ABS PLASTIC	1	202.121
	MOBILE BOWL COVER – STAINLESS STEEL GRILL	1	202.118C
	MOBILE BOWL COVER – STAINLESS STEEL (MODEL WITH GAS STRUTS)	1	202124
2	FIXED BOWL COVER IN ABS PLASTIC	1	205.077
	FIXED BOWL COVER IN STAINLESS STEEL FOR ABS/GRILL	1	205.080
	FIXED BOWL COVER IN STAINLESS STEEL FOR MODEL WITH GAS STRUTS	1	205.082
3	PIN (FIXED/MOBILE COVERS-ABS/ABS)	4	186.092
	PIN (FIXED/MOBILE COVERS-ABS/GRILL)	4	186.092
	PIN (FIXED/MOBILE COVERS-STAINLESS STEEL/GRILL OR ABS)	4	186.095
	PIN (FIXED/MOBILE COVERS-STAINLESS STEEL/STAINLESS STEEL MODEL WITH GAS STRUTS)	4	186.095
4	LEFT ARM (STANDARD MODEL)	1	118.027
	LEFT ARM (MODEL WITH GAS STRUTS)	1	118.053
5	BUSH	2	116.040
6	PIN	2	C00089
7	BUSH	2	C00864
8	SELF-LOCKING NUT GUK	2	C00839
9	PIN	2	186.023
10	SCREW STEI-C M 6x 10 BRUNITO	1	C00042
11	CAM FOR MICROSWITCH (MODEL WITH ELECTRONIC CONTROL PANEL)	2	131.001
	CAM FOR MICROSWITCH (MODEL WITH DIGITAL TIMERS)	1	131.001
12	RING	2	C00240
13	N/A	-	-
14	RIGHT ARM (STANDARD MODEL)	1	118.028
	RIGHT ARM (MODEL WITH GAS STRUTS)	1	118.052
15	WASHER	2	211.001
16	PIN	2	186.004
17	GAS STRUT (MODEL WITH GAS STRUTS)	2	C00261

N/A: Not applicable

N.B.

(i) Technical data is not binding. The data can be changed in order to improve the product.

(ii) Drawings and illustrations are only indicative.